



INSTALLATION INSTRUCTIONS

RETRACTED RECESSED EMERGENCY LIGHTING UNIT GENERATION II

IMPORTANT SAFEGUARDS

When using electrical equipment, basic safety precautions should always be followed including the following:

READ AND FOLLOW ALL SAFETY INSTRUCTIONS

1. Before wiring to power supply, disconnect power at fuse or circuit breaker.
2. Disconnect A.C. power before servicing.
3. Refer to wiring instructions sheet for proper connections.
4. Consult your local building code for approved wiring and installation.
5. Do not use outdoors.
6. Do not mount near gas or electric heaters.
7. Use Caution when servicing battery.
8. Equipment should be mounted in locations and at heights where it will not readily be subject to tampering by unauthorized personnel.
9. The use of accessory equipment not recommended by the manufacturer may cause an unsafe condition.
10. Do not use this equipment for other than intended use.
11. Servicing of this equipment should be performed by qualified service personnel.

SAVE THESE INSTRUCTIONS

CONSERVER LA FICHE D INSTRUCTION

2575 Metropolitan Drive • Trevose • PA 19053 U•S•A
Telephone: (215) 244-4204 • Fax: (215) 244-4208

BACKBOX INSTALLATION

**DO NOT INSTALL SPLICE BOX COVER INTO BACKBOX
UNTIL WIRING IS COMPLETE**

BAR HANGERS



Bar Hangers telescope when assembled adjust from 14-1/2" to 24"

Figure 1

ROUGH-IN CEILING MOUNT

SUPPORTING MEMBERS MUST BE ABLE TO SUPPORT A LOAD OF AT LEAST 25 LBS.

Up to 2" high T-Bars

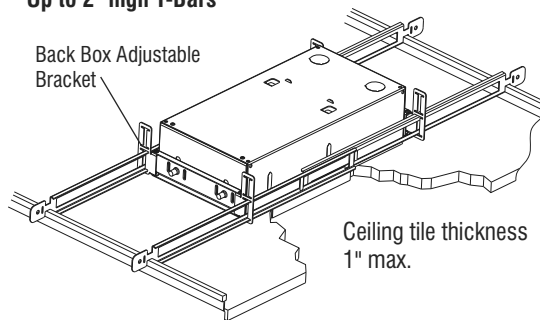

Figure 2

To install backbox onto t-bars, orient the back box adjustable brackets to allow the hanger bars to slide through the "I" shaped opening (Figure 2). **(NOTE: to access the hardware for the hanger bar adjustment brackets, you must remove the splice cover and/or the battery. Refer to page 4 for instructions on removing the splice box cover, figure 7 and 8).** Adjust the height of bracket, mounted to the backbox, then tighten bolts inside the backbox. Hanger bars will rest directly on drop ceiling t-bars.

Align backbox so lamp head opening is flush or slightly behind inner surface of ceiling or wall.

Wood joist or stud mounting

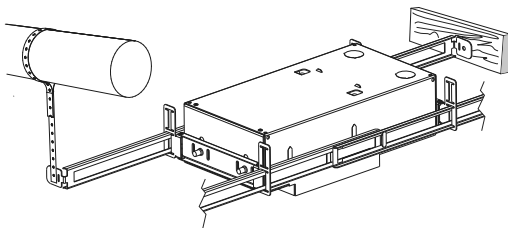

Figure 3

Using hardware supplied by others, attach t-bars to wood studs or joists with screws or nails, attach to metal studs with sheet metal screws with a minimum pullout rating of 25 lbs.

Align backbox so lamp head opening is flush, or slightly behind inner surface of ceiling or wall.

MAXIMUM MOUNTING HEIGHT 47 FEET

UNIT IS APPROVED FOR TYPE IC INSTALLATION.

ROUGH-IN WALL MOUNT

SUPPORTING MEMBERS MUST BE ABLE TO SUPPORT A LOAD OF AT LEAST 25 LBS.

Remove appropriate knockouts on side of backbox for stud mounting. Using hardware supplied by others, attach t-bars to wood studs or joists with screws or nails, attach to metal studs with sheet metal screws with a minimum pullout rating of 25 lbs.

Align backbox so lamp head opening is flush, or slightly behind inner surface of ceiling or wall. Secure in place by tightening the bolts inside the backbox. (**NOTE: SPLICE BOX NOT SHOWN FOR CLARITY**)

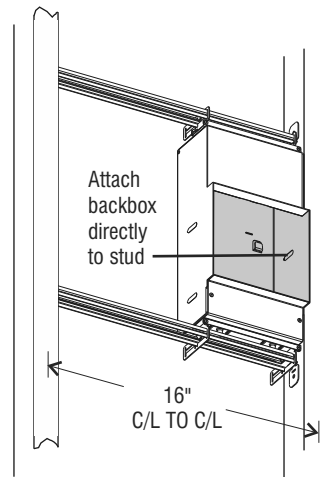

WALL MOUNT

Figure 4

CLOSE-IN CEILING AND WALL MOUNT

DRY WALL:

Cutout hole in ceiling material should be 5-1/4" high by 5-1/2" wide (Figure 5). Align backbox so lamp head opening is flush, or slightly behind inner ceiling or wall surface.

WET WALL:

Plaster flush up against lamphead opening.

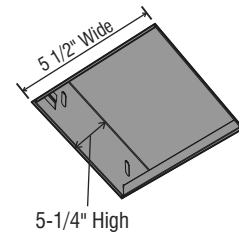

Figure 5

WIRING INSTRUCTIONS

DE-ENERGIZE BRANCH CIRCUIT AT BREAKER PANEL

Select and remove desired knockout(s) for AC power input (Figure 6) with at least 6" of AC power leads extending into backbox.

Back Box Rear View with Knockouts

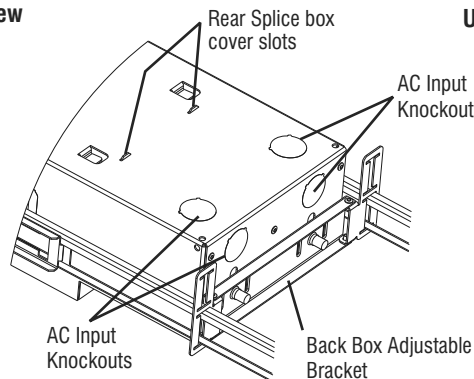

Figure 6

DO NOT REAPPLY POWER UNTIL FINAL SETUP

REMOVING SPLICE BOX

Remove the splice box cover to gain access to the transformer leads and ground wire. Place a flat head blade screw driver into the slot on the splice box cover to help to pull the splice box tabs from the bottom of the back box as shown below.

Gently pull on tab (in the direction shown) to relieve tension from the tabs on top of the splice box cover while simultaneously pulling up on the screw driver handle.

CAUTION: DO NOT PUSH DOWN ON THE SCREW DRIVER AS THIS MAY CAUSE DAMAGE FLANGE BELOW.

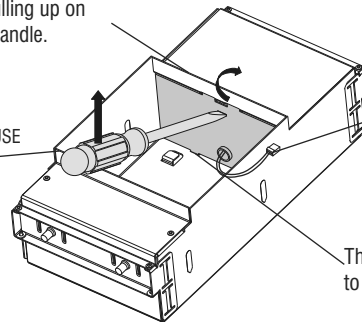

Care to be taken to remove transformer wires away from sharp edges during the removal of the splice box cover.

This motion will allow the bottom tabs to disengage from the back box

Figure 7

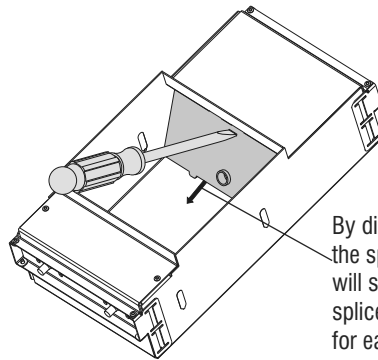

By disengaging the bottom tabs, the splice box cover tabs on the top will slide out of their slots and the splice box cover will rotate free allowing for easy removal to terminate the transformer leads.

Figure 8

WIRING INSTRUCTIONS CONT.

DE-ENERGIZE BRANCH CIRCUIT AT BREAKER PANEL

Transformer primary leads are secured to splice plate. Make connections using wire nuts supplied. Connect wires per local codes. Connect to transformer as follows:

BLACK Lead for **120V** or
ORANGE Lead for **277V**
(CAP UNUSED LEAD)

WHITE Lead for **Neutral**

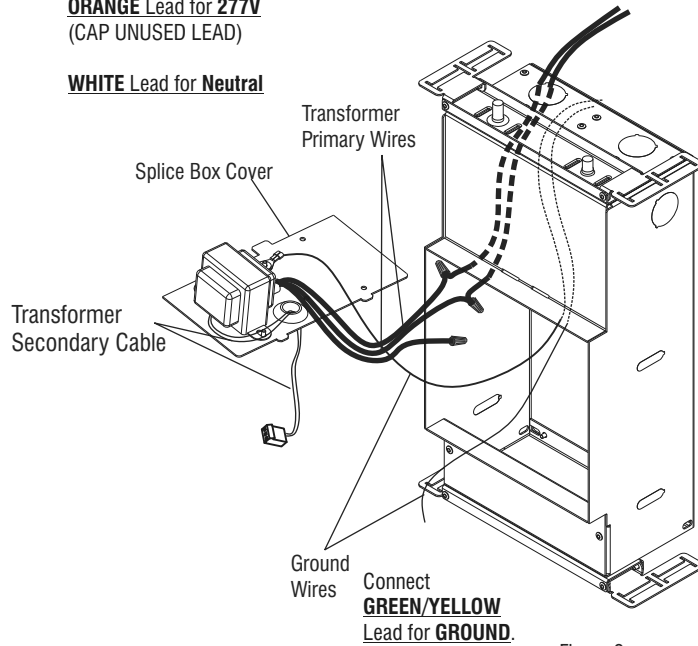

Figure 9

INSTALL SPLICE BOX COVER

Rotate splice box cover to the orientation shown. CARE TO BE TAKEN THAT ALL WIRES ARE AWAY FROM THE SHARP EDGES AND TUCKED INSIDE THE SPLICE BOX.

Tabs on splice box cover to align with slots on backbox flange.

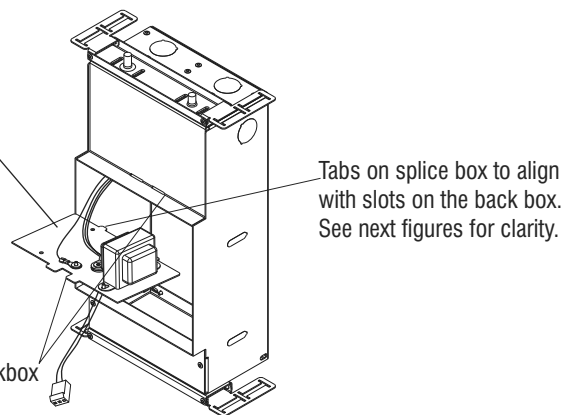

Figure 10

INSTALLING SPLICE BOX CONTINUED

Once the splice box cover is oriented per Figure 10, the steps to securing the splice box into the backbox is the same as the removal process, in reverse.

Engage splice box cover tabs into backbox, as shown.

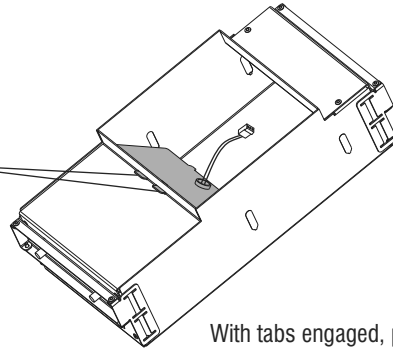

Figure 11

CARE TO BE TAKEN SUCH THAT NO WIRES ARE PINCHED IN THE PROCESS OF INSTALLING THE SPLICE BOX.

With tabs engaged, push along bottom edge until the lower tabs are engaged and splice box is in place

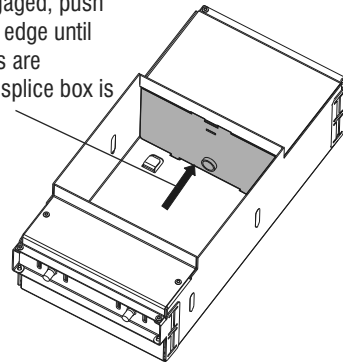

Figure 12

BATTERY INSTALLATION

THIS PRODUCT IS SUPPLIED WITH NICKEL METAL HYDRIDE (Ni-MH) BATTERIES. The batteries are located on the "bottom" side of the backbox, opposite the transformer assembly/ splice box (as shown below).

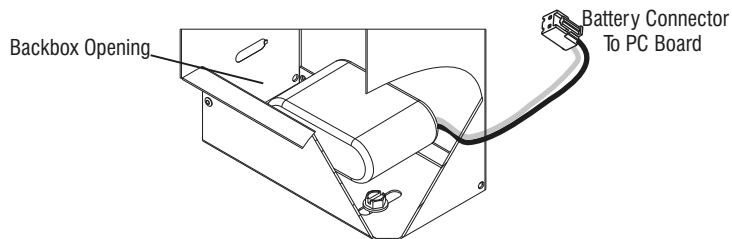

Figure 13

NOTE: Disconnected Battery must be recharged within 120 days.

LAMPHEAD INSTALLATION

Connect 2 pin Battery Cable first, then 3 pin Transformer Cable to matching sockets on Printed Circuit Board. **BATTERY CABLE, WITH BATTERIES CONNECTED, MUST BE ATTACHED BEFORE AC POWER IS APPLIED.**

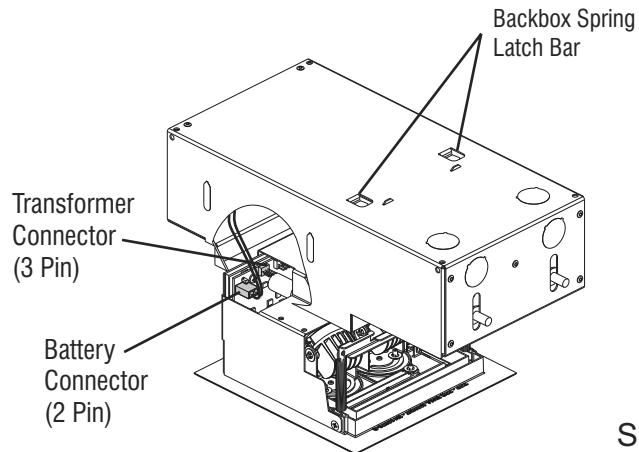

Figure 14

NOTE:
Once Battery is connected, unit must be energized within 30 days.

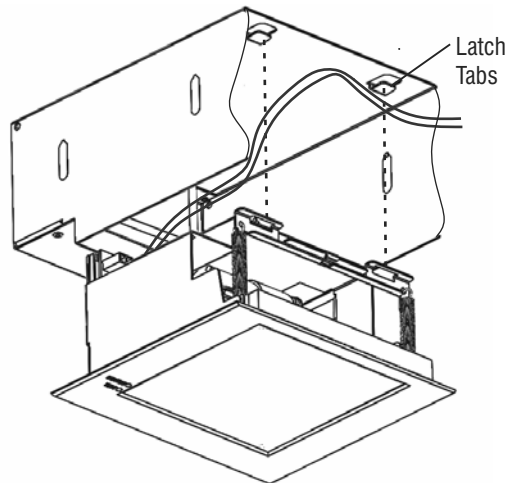
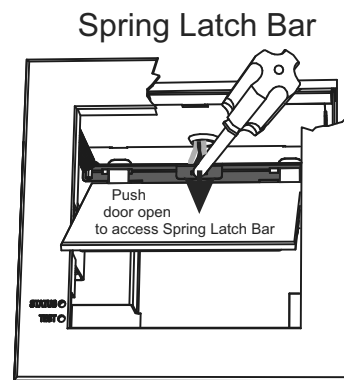

Figure 16



Insert Phillips screwdriver into hole as shown, push down and forward to engage latches.

Figure 15

Install lamphead by first locating in place in Backbox opening.

With pivoting door held open, insert Phillips screwdriver tip into center hole in Spring Latch Bar, push down and forward to engage bar under two formed latch tabs in rear of Backbox.

Transformer secondary cable must be trapped behind Latch Bar to prevent interference with pivoting door.

LAMP ADJUSTMENT

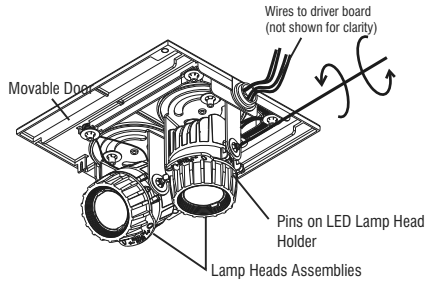

Figure 17

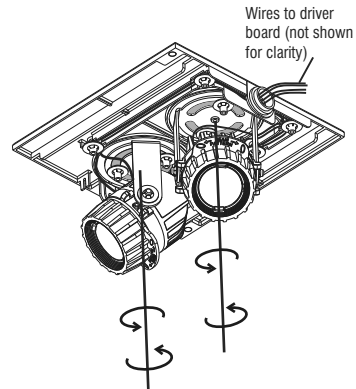

Figure 18

This Fully Recessed Emergency Light has two adjustable LED assemblies mounted on the moveable door. To aim the heads rotate the LED assemblies by pivoting the head 180degrees on the lamp head holder pins, as shown (highlighted in gray).

For wall mounting applications, the LED assemblies should be aimed down toward the floor. For ceiling mounting, the LED assembly should be aimed straight out to the path to be illuminated.

The lamp heads can also be oriented to a specific area buy rotating the lap head holder before or after the lamp heads have been positioned.

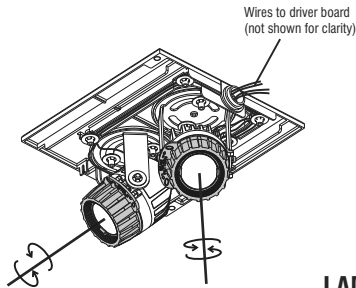

Figure 14

Once the lamp head has been aimed and oriented per the steps above, adjust the beam angle to the desired shape by rotating the lens holder 90 degrees.

LAMP HEAD ASSEMBLY

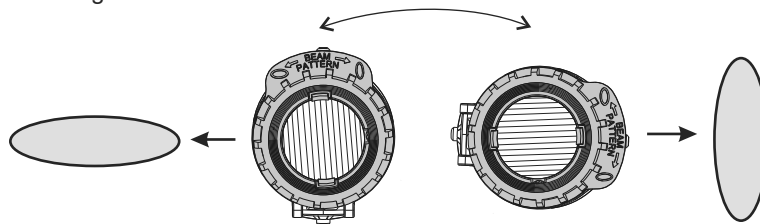

Figure 19

Each lamp head can be rotated a maximum of 90 degrees. It is best to use the markings on the lens to determine the beam pattern to be projected on the floor. The beam pattern is always perpendicular to the lines/ ripples in the lens.

ON-SITE PAINTING

The door and frame have been factory painted. If a new finish is applied, extreme care should be taken that a seal is not formed between the door and frame, which may hinder the free operation of the door mechanism.

If the finish is sprayed on, we suggest that a thin cardboard or plastic strip be inserted between the door and frame to prevent a paint seal. The indicator light and test switch holes should also be masked.

After the new finish is applied, a sharp edge such as a single edge razor or utility knife should be inserted a maximum of 1/4 inch into the opening between the door and frame, and run around the door to ensure no seal is formed.

UNIT WITH DOOR OPEN

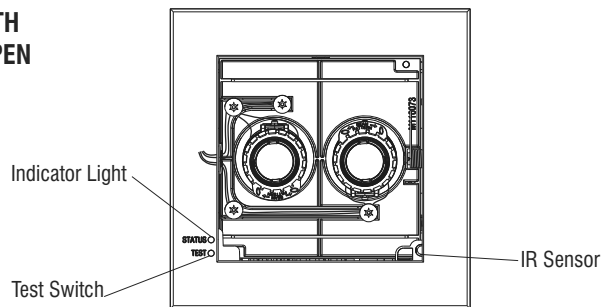

Figure 20

SETUP AND OPERATION

REAPPLY POWER AND NOTIFY THE AUTHORITY HAVING JURISDICTION.

ALLOW BATTERIES TO CHARGE FOR AT LEAST 48 HOURS BEFORE OPERATING UNIT.

STATUS - See following pages for Status indications.

TEST - The "TEST SWITCH" is used to simulate failure of AC power. It can be activated with a paper clip.

INFRA RED REMOTE TESTING - To activate TRANSMITTER, remove tab from back of device. The "IR REMOTE TESTING TRANSMITTER" can activate the unit up to 50 feet. By aiming TRANSMITTER at face of unit and pushing either "30 SECOND" or "90 MINUTE" button for 1 second, AC power failure will be simulated for the selected duration. The test can be cancelled by pushing button again.

TIME DELAY - A 15 minute time delay is available as a factory option. This option will keep the unit operating on battery backup for 15 minutes after power is restored.

CCEA APPROVAL - Approval for CCEA City of Chicago Environmental Airspace is available as a factory option.

SELF-TESTING / SELF-DIAGNOSTICS

This unit meets the requirements of NFPA 101 for Periodic Testing of Emergency Lighting Equipment. It provides visual indication of unit malfunctions including:

Battery Fault
Charger Fault
Transfer Fault
Lamp Fault
Door Fault

SELF-TEST

An automatic self-test and diagnostic function will be performed every 28 days. A load test will be performed for 30 seconds checking for a lamp, battery or transfer fault. On every fourth test, the load test will follow a door function test, during which the door will open for approximately 1 second and then close, without the lamps turning on. This automatic self-test and diagnostic function will be performed only if the battery is fully charged. If not, the test will automatically reschedule. The charger function is monitored continuously.

DEFEAT MONTHLY DIAGNOSTICS TESTING - The option to defeat the standard monthly testing is available as a factory option. This will allow the user to bypass the testing schedule that is provided standard with all units.

USER-TEST

A manual USER-TEST can be performed for 30 seconds or 90 minutes. By pushing the "TEST" Switch for 1 second, the door will open and the lamps will illuminate for 30 seconds. If the "STATUS" indicator shows GREEN indicating a fully charged Battery and the Switch is pushed for 4 seconds, the door will open and the lamps will illuminate for 90 minutes. If the Battery is not fully charged, the 30 second test will run.

In either mode, the USER-TEST can be cancelled by pushing and holding the "TEST" Switch for 1 second after the lamps come on.

LAMP LOAD LEARN

The self-diagnostic system "learns" the lamp load during the first test. Subsequent tests compare the measured lamp load during the test to the learned lamp load values.

CLEARING FAILURE INDICATIONS

Failure indications can be cleared by correcting the indicated fault and pushing and holding the "TEST" Switch for 1 second.

STATUS INDICATIONS

Status indications for the self-testing / self-diagnostic system are shown on the following page.

STATUS INDICATIONS

STATUS DISPLAY	FUNCTION	ACTION
Continuous Green	Battery in Float / Trickle Charge	None
Continuous Red	Battery High Charging	Wait for Green Status
Flashing Green	In Test Mode	Wait for Test to Complete
Alternate Red and Green	Insufficient Charge For User Test	Wait for Adequate Charge*
Red One Blink ON / Pause	Transfer System Failure	Factory Service
Red Two Blinks ON / Pause	Battery Failure	Check Connections / Replace Battery
Red Three Blinks ON / Pause	Charger Failure	Factory Service
Red Four Blinks ON / Pause	Door Failure	Check for Paint Seal
Red Five Blinks ON / Pause	Lamp Failure	Replace Lamp

* For 90 minute User Tests, wait for full charge.
For 30 second User Tests, try again after an hour of charging.

MAINTENANCE

REMOVAL OF SPLICE BOX COVER - Splice Box Cover can be removed from backbox by prying forward the top, front flange of the backbox with a flat blade screwdriver.

BATTERY - The battery supplied in this unit requires no maintenance. It will be periodically tested by the SELF-TESTING / SELF-DIAGNOSTIC system according to the requirements of NFPA 101. If battery replacement is required, replace using the BATTERY INSTALLATION procedure. If unit was supplied with a Lead Calcium (LC) battery, replace with part number B250010 only. If unit was supplied with a Nickel Cadmium (Ni-Cd) battery, replace with part number B310014 only. If unit was supplied with Nickel Metal Hydride (Ni-MH) battery, replace with part number B350004. Do not interchange battery types.

Used batteries may not be disposed of in the municipal solid waste stream. Arrangements for recycling batteries can be made by contacting www.call2recycle.org