

# PWII

## 125VA – 550VA Dimming Inverter

The Pure Wave II (PWII) was built upon our industry proven PW-Series to engineer a new Dimmable Class of Lighting Inverters with serviceability and flexibility at the forefront of design. Equipped with Pure Sine Wave output, 10X crest factors to punch through the most demanding inrush requirements, 3 or 4 (model specific) configurable lighting zones for seamless system integration, field-selectable Input/Output AC voltages, and ultra-low standby power consumption to meet the California Energy Commission requirements. The PWII offers an industry-leading option of up to 4 channel (model specific) DALI / 0-10V transfer circuits with independent selectable preset dimming levels for each output



### QUICK SPECS

Input Voltage	120/277 VAC Field Selectable
Max Connected Load	Up to 375W for 120W and 250W models, Up to 1,125W for 375 and 550W models
Output Voltage	120/277 VAC Field Selectable
Output Power	125W (PWII-12), 250W (PWII-25), 375W (PWII-37), 550W (PWII-55)
Load Type	LED, Fluorescent, Incandescent
Transfer Time	50ms / 1S / 2S User Selectable
Operating Time	90 Minutes
Overload Capability	Up To 110%
Frequency Regulation	60Hz +/- 002 Hz crystal controlled
Crest Factor	10X (125W), 5X (250W), 75X (375W), 5X (550W)
Load Power Factor	0.5 lead to 0.5 lag
Operating Temperature	20 - 30 °C
Battery Type	Valve Regulated Lead Acid (VRLA)
Approval	UL924 Listed

### WARRANTY

- Electronics are warranted for 3 years, extended out to 5 years with the purchase of Factory Phone Startup (option PS).
- VRLA batteries have a 10-year warranty consisting of 3 year full and 7 years pro-rata - view complete warranty terms online at [www.evenlite.com/terms-warranty](http://www.evenlite.com/terms-warranty).
- An extended warranty is available with the purchase of Factory Phone Startup (PS). The Extended Warranty increases electronics coverage to five years. For complete details, please refer to the Central Power Systems Warranty.

### FEATURES

- Field-selectable 120 or 277 VAC Input/Output
- User adjustable transfer time for application flexibility
- Provides 3 (125/250W models) or 4 (375/550W models) individually controlled DALI / 0-10V zones each with 5 preset levels of 100%, 80%, 60%, 40% & 20%
- FD option includes Fire Alarm 0-24V AC/DC interface
- 1x Normally-On, 3 or 4x (model specific) configurable types for ultimate load flexibility
- Advanced Startup, Charger, and Inverter Diagnostics for prevention of field failures, overloads and miswires
- Automatic Self-Testing / Self-Diagnostics included as standard
- High purity premium maintenance-free Valve Regulated Lead Acid (VRLA) batteries with thicker plates for long standby life and durability (10-12 year design life)
- T-Bar Mount available in 125 watt model

### INPUT

- Voltage: 120 or 277 VAC – field configurable
- Current: 125W Model 1.4A @ 120V, 0.6A @ 277V  
250W Model 2.7A @ 120V, 1.2A @ 277V  
375W Model 4.10A @ 120V, 1.19A @ 277V  
550W Model 5.95A @ 120V, 1.98A @ 277V
- Frequency: 60Hz +/- 2 Hz
- Protection: Easy access 8A fast acting 5x20 mm fuse.
- Power Factor: 0.5 lead to 0.5 lag

## OUTPUT

- Voltage: 120 or 277 VAC (follows Input Voltage selection)
- Current: 125W Model 1.04A @120V, 0.45A @ 277V  
250W Model 2.08A @120V, 0.9A @277V  
375W Model 3.12A @120V, 1.35A @ 277V  
550W Model 4.85A @120V, 1.98A @277V
- Frequency: 60Hz +/- 0.02 Hz crystal controlled (EM mode)
- Overload Capability: Up to 110%, @ 110% unit will generate overload fault
- Configurable Transfer Times: 50ms, 1s (default), 2s
- Output Distortion: Less than 3% THD
- Crest Factor: 10X for 125W, 5X for 250W, 7.5x for 375W and 5x for 550W model
- Load Power Factor: 0.5 lead to 0.5 lag
- Output Types: 1x Normally-On, 3x configurable Normally-Off/Switched, for 125 and 250W Models, one normally on and 4x configurable Normally-Off/Switched for 375 and 550W Models
- Max Connected Load w/ Dimmer option: 375W for PWII-12 & PWII-25; 1,125W for PWII-37 & PWII-55 (Non-EM Mode)

## CONSTRUCTION

- NEMA Type 1 enclosure:  
PWII 12 & 25, 18Ga epoxy powder coated Cold Rolled Steel (CRS)  
PWII 37 & 55, 14Ga epoxy powder coated Cold Rolled Steel (CRS)
- Cooling by natural convection – no internal fans
- Electrical Knock Outs (EKO's) for ½" and ¾" conduit provided on three surfaces

## BATTERY

- Long-Life Valve-Regulated Lead Acid (VRLA)
- Ultra efficient 3-rate, temperature-compensated charger PW
- Automatic Low Voltage Disconnect (LVD) set at 1.67 VPC
- 24 Hour Recharge Time
- Runtime: 90 Minutes at 25C°
- DC Voltage: 24 VDC Nominal, 2.27 VPC float, temperature compensated
- DC Current: 6.2/12.4 ADC Nominal (125/250 Watt model)  
18.25/27 ADC Nominal (375/550 Watt model)

## ENVIRONMENTAL

- Operating Temp: 20C° to 30C°
- Storage Temp: Electronics – 20C° to 70C°, Batteries – 0C° to 40C°
- Relative Humidity: <95 % (non-condensing)

## CERTIFICATIONS & COMPLIANCE

- UL924 Certified
- NEMA 410 load tested up to 375W (125,250W models), 1,125W (375, 550W models)
- NFPA 101 Life Safety Code
- NFPA 70 – NEC
- New York City approved, Calendar Number 51575
- NEMA Type 1 Enclosure
- Buy American Act compliant

## ORDERING GUIDE

PWII-25-LC-FD

MODEL	WATTAGE/VA	BATTERY TYPE	OPTIONS
<b>PWII</b>	<b>12</b> 125 Watts/VA	<b>LC</b> Lead Calcium	<b>FD</b> 3 or 4 <sup>1</sup> Independent Dimming Zones <sup>2</sup> / 1 x Fire Alarm Interface
	<b>25</b> 250 Watts/VA		<b>AA</b> Audible Alarm
	<b>37</b> 375 Watts/VA		<b>DT</b> 2 Second Delayed Transfer
	<b>55</b> 550 Watts/VA		<b>RT</b> Remote Test Switch and Monitor <sup>3</sup>
			<b>TLRT</b> Infrared Remote Hand Held Transmitter for [RT] <sup>4</sup>
			<b>TB</b> T-Bar Mount Housing <sup>5</sup>
<b>PWII</b>		<b>LC</b>	
OPTIONAL DIMMING PRESET			ORDERING NOTES
<b>(BLANK)</b>	No Factory Set Dimming		<ol style="list-style-type: none"> <li>1 Number of dimming zones is model dependent.</li> <li>2 Dimming via 0-10V/DALI; See <b>Optional Dimming Preset</b></li> <li>3 [RT] option also includes Audible Alarm, IR receiver, Test Switch and SD Indicator</li> <li>4 Order Separately</li> <li>5 125 Watt Only</li> <li>6 Reduced to 100W and 200W respectively</li> <li>7 Electronics are warranted for 3 years, extended out to 5 years with the purchase of Factory Phone Startup (option PS).</li> </ol>
<b>Output 1</b>	11=100% 12=80% 13=60% 14=40% 15=20%		
<b>Output 2</b>	21=100% 22=80% 23=60% 24=40% 25=20%		
<b>Output 3</b>	31=100% 32=80% 33=60% 34=40% 35=20%		
<b>Output 4</b>	41=100% 42=80% 43=60% 44=40% 45=20%		

Fill in fields from categories above and complete type and part number.

Type No:

Full Part No:

**WEIGHT & DIMENSIONS**

PWII-12

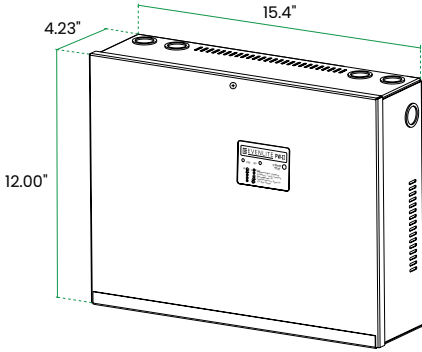

PWII-12 T-BAR

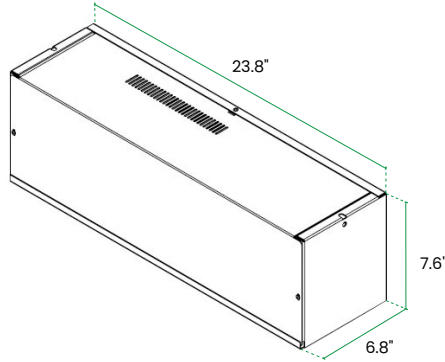

MODEL	INVERTER WEIGHT	BATTERY WEIGHT
PWII-12	33 lbs.	INCL
PWII-12 T-Bar	36 lbs.	INCL
PWII-25	29 lbs.	37 lbs.
PW37	43 lbs.	57 lbs.
PW55	43 lbs.	77 lbs.

PWII-25

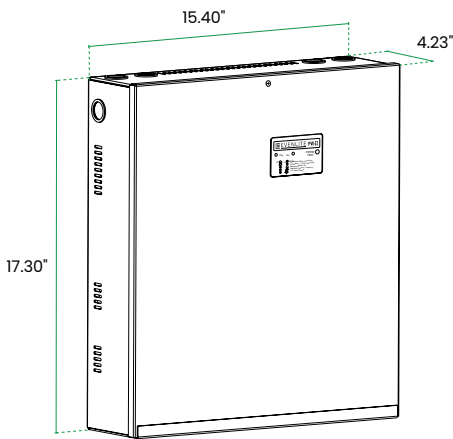

PWII-37, PWII-55

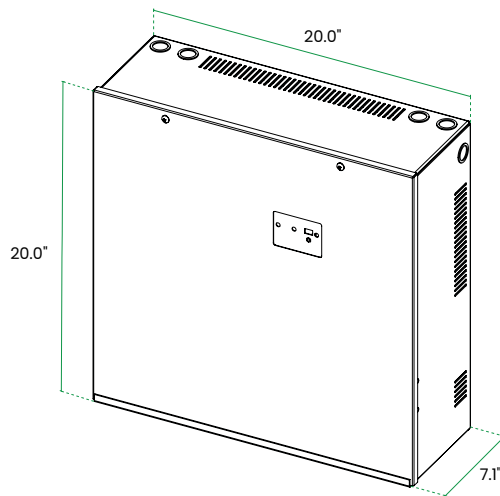

**SYSTEM PANEL**

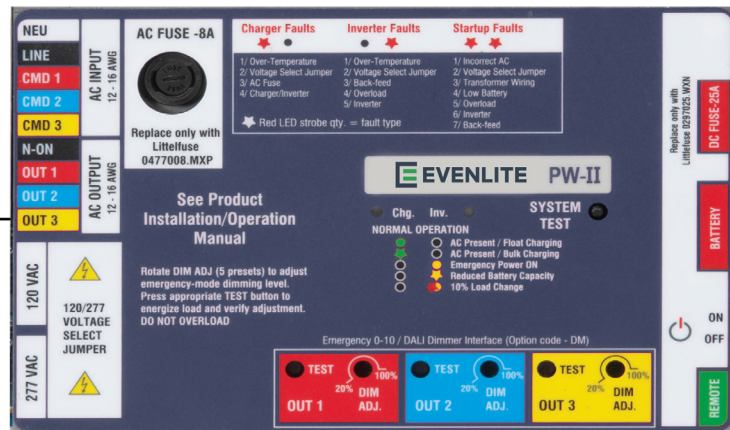
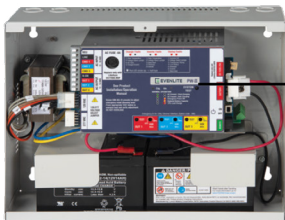

### DIMMING EXPLAINED

The Diagram to the right is an example of a typical wiring application where a single Area/Room contains both Normal Lights and Emergency Lights. The PWII passes the 0-10V signal through itself when Utility power is present.

Once in EM Mode, the PWII bypasses the Area/Room dimmer and supplies the 0-10V Dimming Signal based on the internally adjustable Preset Level for that Zone.

Preset Level Options are as follows: 100%, 80%, 60%, 40% or 20%

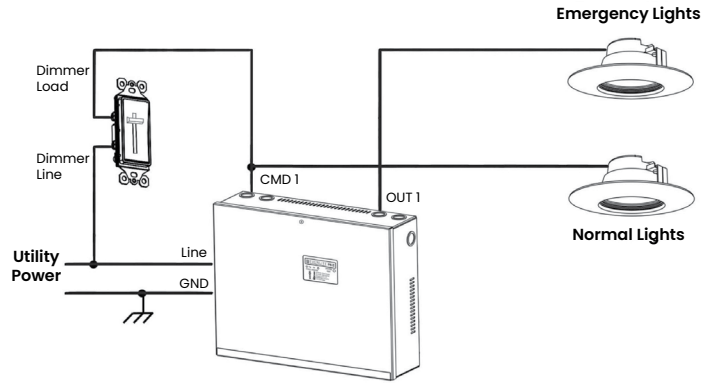

### 3-ZONE DIMMING EXAMPLE

The Diagram below is an example of utilization of the PWII-12's three independent Zones in three separate rooms. In each room there are 5 Emergency Fixtures connected to an Inverter Zone Output. Each fixture represents a 25 Watt fixture, with that same fixture used for both Normal and Emergency application. When in Normal Mode, the inverter directly couples the Dimmer Line Output and Dimmer 0-10V signal to the connected Emergency Fixtures; allowing those fixtures to output up to "Full On" for a maximum pass-through load of 375 Watts. When in Emergency Mode, The PWII will output based upon the Internal Preset Level for each zone bypassing the dimmer control for a total Emergency Load of 100 watts.

#### **NORMAL MODE (PASS THROUGH)**

Room 1-5 Fixtures X 25W @ Full On = 125W  
 Room 2-5 Fixtures X 25W @ Full On = 125W  
 Room 3-5 Fixtures X 25W @ Full On = 125W  
 Total Wattage = 375W

#### **EMERGENCY MODE (INTERNALLY DIMMED)**

Room 1-5 Fixtures X 25W @ 20% Preset = 25W  
 Room 2-5 Fixtures X 25W @ 40% Preset = 50W  
 Room 3-5 Fixtures X 25W @ 20% Preset = 25W  
 Total Wattage = 100W

