

PH100

100' Photoluminescent Exit Sign

The PH Series offers a sleek, high-performance photoluminescent exit sign with a 100-foot viewing distance, housed in an attractive Slimline ABS casing with a universal mounting canopy. Designed for effortless installation and maintenance-free operation, it has an expected lifespan of a 25+ years of reliable service. Its sustainable design makes it ideal for green buildings, and it is recyclable at the end of its life. Rated for a 50-foot viewing distance, the PF Series requires only 5 foot-candles (54 lux) of light for activation during times of building occupancy.



CONSTRUCTION

- PH Series is constructed using a pure white ABS housing and photo luminescent panel
- Stencil face with green Photo luminescent letters and a silver/gray outline provide high contrast and visibility
- Universal field selectable chevron directional indicators are included with each sign
- Single or double face models available and are suitable for over the door or low mounting requirements
- Signs can be easily relocated in the event of building renovations or changes in the designated egress path

ILLUMINATION

- Activation requires only 5 foot-candles (54 lux) of unfiltered fluorescent, LED, Metal Halide, or Mercury Vapor lighting for 60 minutes (must be externally illuminated during normal building occupation)
- Proprietary high-density phosphors used to meet the 100-foot viewing requirement

CERTIFICATION

- 7" high letters with a 7/8" stroke provides 100' UL listed viewing distance
- PH100 was tested and listed per UL924 requirements for use with LED lighting
- PH Series photo luminescent exit signs are LEED point qualified and recyclable at the end of their useful life
- Tested and listed to UL 924, meets NFPA101 Life Safety Code and OSHA requirements
- Buy American Act Compliant

WARRANTY

- 3 year pro-rata fixture warranty - view complete warranty terms online at www.evenlite.com/terms-warranty.

ORDERING GUIDE

PH-100-1-WH-U

MODEL	NO. OF FACES	HOUSING COLOR	MOUNTING
PH100	1 Single Face	WH White	U Universal Mounting Canopy Included
	2 Double Face		
PH100		WH	U

Fill in fields from categories above and complete type and part number.

Type No:	Full Part No:
----------	---------------

DIMENSIONS

WALL MOUNT

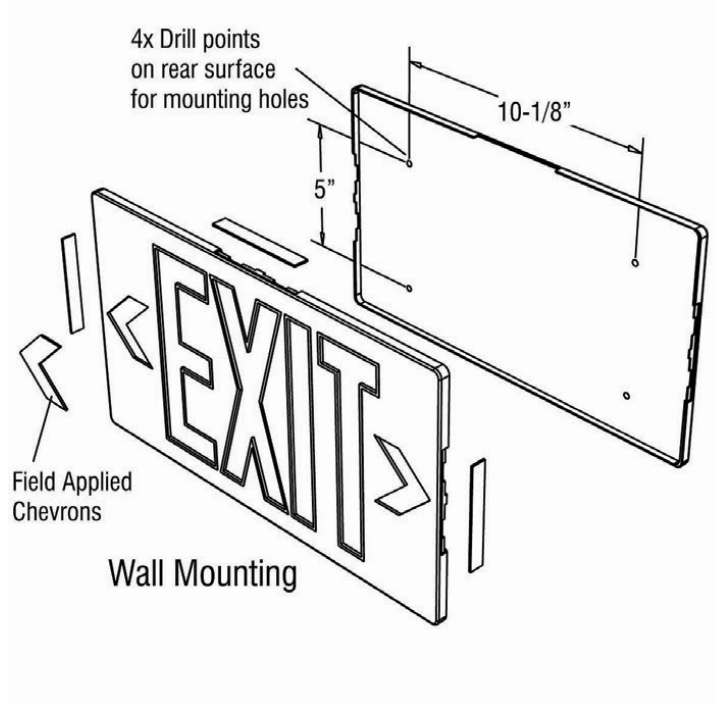

CANOPY MOUNT (SINGLE & DOUBLE FACE)

