

LITEMINDER SPLIT PHASE

2,200VA – 12,500VA Central Inverter System

The LiteMinder Central Inverter System provides an innovative Emergency Lighting solution for today's complex energy-saving systems, light sources, and maintenance requirements. LiteMinder represents the pinnacle of engineering excellence with features not found in the traditional systems currently available.



DESCRIPTION

- **Modularity:** LiteMinder features unique inverter modules available in increments from 2,200VA to 12,500VA capacities. Modules are interconnected to build the required system capacity, and can even be field upgraded to increase system sizes!
- **Control Features:** A keypad and LCD display provides user interface and extensive status diagnostics. Self test, Self-Diagnostics, in compliance with UL 924, is field configurable.
- **Web Site Monitoring:** Unique web interface constantly monitors the system status and records all essential data. Users can log on, view, interact and download records as needed. The factory can also monitor, diagnose remotely. Website monitoring free on every inverter (must use option code LGM).
- **Diagnostics:** In addition to Self-test, Self-Diagnostics, LiteMinder also includes unique startup diagnostics to aid in installation and maintenance: eight individual startup alarms (Communications, Set-Up Conflict, Low Battery, Back-feed, Transfer/AC Fuse, Short/Overload, Miswire, Incorrect AC Input) eight individual Charger Alarms and eight individual Inverter Alarms.

SPECIFICATIONS

- PWM MOSFET and IGBT (Model Dependant) Inverter provide Pure Sine Wave output with less than 3% THD, and fully compatible with LED Lighting Loads
- Fast transfer for H.I.D. compatibility ensures smooth operation of combined lighting loads, transfers in less than 2 mS
- Less than 3% THD, load power factor 0.5 Lag to 0.5 Lead, 98% efficient in standby mode
- Automatic Low Voltage Disconnect (LVD) set at 1.67 VPC
- Shorted circuit protected to 65KAIC tested and approved to UL 6180-5-1 standard
- Crest factor >4 for high inrush demanding loads, overload 120 percent for 10 minutes, 400 percent for 500mS
- VRLA Maintenance Free Lead Calcium Battery's provide the required 90 minute minimum run time in emergency mode
- Battery recharge time is less than 24 hours, meets all UL 924 and NFPA101 Life Safety Code requirements
- Operating temperature 20° to 30° C
- Brownout protection set for 85% of the nominal line voltage

FEATURES

- Modular inverter allows operation for split phase operation to order
- Automatic restart upon utility power return, no need to manually reset the system
- Input circuit breaker is provided sized to system rating
- Monthly and the annual 90 minute test can be programmed by the user for a specific date and time to ensure NFPA Code Compliance
- Up to 1000 events stored in the memory log on a "FIFO" basis, and is easily accessible thru the MMI (Man-Machine Interface) Panel
- MMI consists of a 5 button keypad for easy menu navigation
- A 4x20 backlit White display with heads-up LED's allow for a quick diagnosis of the system status and alarms
- Five LED indicators provide the status of the Inverter, Charger, AC present, Ready, and Switched Load (if provided with Switched Output Circuit Breakers)
- A dedicated System Test button is provided for a user initiated 30 second on demand test
- An Alarm On/Off LED is provided to indicate that an alarm is present.
- A dedicated Alarm Silence On/Off push button allows the user to silence the audible alarm
- SD card slot allows the user to download all Test, Event and Alarm Logs
- The Meter Menu allows the user to access the Input and Output Voltages, Output Current, Output VA, Battery Voltage, Battery Current, Battery Power, Temperature, System Days, Inverter minutes and Inverter Events
- The inverter and battery cabinets are constructed from 14 gauge CRS and are powder painted with no visible hardware
- Internally, the inverter has all galvanized or painted steel parts for all modules and shelves to resist corrosion and provide high durability and longevity
- Installer friendly front mounted battery terminals for easier and faster installation
- Three Rate Charger circuit is fully temperature compensated for added reliability

CERTIFICATION

- UL924 compliant Self-Test/Self-Diagnostics are standard, with interactive LCD display (MMI)
- Listed to UL924, and meets NFPA101 Life Safety Code, NFPA70-NEC and OSHA Requirements, 1.0–2.8KVA models meet CSA C22.2 No. 141-10
- Buy American Act compliant
- Trade Agreements Act compliant

WARRANTY

- Electronics are warranted for 2 years, extended out to 3 years with the purchase of factory startup. VRLA batteries have a 10-year warranty consisting of 1 year full and 9 years pro-rata – view complete warranty terms online at www.evenlite.com/terms-warranty.
- An extended warranty is available with the purchase of Factory Startup (FS). The Extended Warranty increases electronics coverage to five years. For complete details, please refer to the Central Power Systems Warranty.
- An extended battery warranty is also available, offering coverage periods of either 15 years (EB15) or 20 years (EB20), as specified in the Ordering Guide. This warranty includes one year of full replacement coverage at no charge, followed by 14 (EB15) or 19 (EB20) additional years of pro-rata coverage.

ORDERING GUIDE

LM-12500-1S-LC-ID-OD-S4-TA-Z4-FS

MODEL	VA RATING	CONFIGURATION	BATTERY TYPE	INPUT VOLTAGE	OUTPUT VOLTAGE	
LM	2200 2200VA	1S Split Phase	LC Lead Calcium	ID 120V/120V/240V ¹	OD 120V/120V/240V ¹	
	4200 4200VA					8250 8250VA
	5200 5200VA					10500 10500VA
	6250 6250VA					12500 12500VA
LM		1S	LC	ID	OD	

OUTPUT BREAKER CONFIGURATION ^{2,3}	OPTIONS		
C(n) 20A Normally On Output Breaker	TA Trip Alarm	RA Remote Annunciator	EB20 20 Year Extended Battery Warranty ¹⁰
O(n) 20A Normally Off Output Breaker	TB 1 Summary/2 Programmable Terminal Block ⁵	KE Keyed Lock	UP Ship Inverter Less Batteries
S(n) 20A Switched Output Breaker	MB Internal Maintenance Bypass Switch ⁵	BTMS Battery Thermal Management System	EPO Emergency Power Off ⁵
(n)= Quantity Required	BI BACnet Integration Module	FS On-Site Startup Commissioning	BL Output Breaker Locks ¹¹
BB Special Breaker Current Requirement ⁴	LGM LifeGuard [®] Monitoring	EW 5 Year Extended Warranty ⁷	SK Stacked Cabinet Configuration ¹²
	DT 60ms Delayed Transfer	M(n) Maintenance Plan ⁸	
	Z4 Seismic Zone 4 Certified	EB15 15 Year Extended Battery Warranty ⁹	

ORDERING NOTES

- L-N/L-N/L-L – 3 wire and ground
- See Output Breaker Quantity Limitations table
- Split phase inverters require breakers per phase. Must be specified in multiples of 2.
- Contact factory
- For form C dry contacts
- Reduces maximum output breakers by 2. Make before break.
- Requires On-Site Startup Commissioning [FS]
- N=years (minimum: 2 / maximum: 5)
- 1 full year with 14 years pro-rated
- 1 full year with 19 years pro-rated
- 1 provided per output circuit breaker specified
- Not Seismic Certified

Fill in fields from categories above and complete type and part number.

Type No:	Full Part No:
----------	---------------

OUTPUT BREAKER QUANTITY LIMITATIONS

Any Combination Of Output Types

2200VA	4200 – 12500VA
6X20A Normally On Without [TA]	24X20A Normally On Without [TA]
4X20A Normally Off With or Without [TA]	12X20A Normally Off With or Without [TA]
4X20A Switched With or Without [TA]	12X20A Switched With or Without [TA]
4X20A Normally On With [TA]	16X20A Normally On With [TA]

DIMENSIONS, WEIGHT & LOAD CAPACITY

MODEL	NO. OF CABINETS	CABINET WIDTH	CABINET HEIGHT	CABINET DEPTH	CABINET WEIGHT	BATTERY CABINET WEIGHT	TOTAL BATTERY WEIGHT	TOTAL SHIPPING WEIGHT	MAX BTUS HOUR AT FULL LOAD	MAX CONNECTED LOAD	
										90 MINUTE RUNTIME	120 MINUTE RUNTIME
LM-2200	2	24"	38"	13"	207 lbs	108 lbs	312 lbs	687 lbs	151	2,200 VA	1,650 VA
LM-4200	2	32"	50"	23"	445 lbs	270 lbs	624 lbs	1,519 lbs	287	4,200 VA	3,150 VA
LM-5200	2	32"	50"	23"	445 lbs	270 lbs	780 lbs	1,675 lbs	355	5,200 VA	3,900 VA
LM-6250	2	32"	50"	23"	445 lbs	270 lbs	936 lbs	1,831 lbs	427	6,250 VA	4,687 VA
LM-8250	2	32"	50"	23"	495 lbs	270 lbs	1,248 lbs	2,193 lbs	564	8,250 VA	6,187 VA
LM-10500	2	32"	50"	23"	495 lbs	270 lbs	1,560 lbs	2,505 lbs	717	10,500 VA	7,875 VA
LM-12500	2	32"	50"	23"	495 lbs	270 lbs	1,872 lbs	2,817 lbs	854	12,500 VA	9,375 VA

INPUT CURRENT & BTU CHART

INPUT POWER	INPUT VOLTAGE	INPUT CURRENT	MINIMUM BREAKER REQUIRED	SUGGESTED FEED BREAKER	MAX BTUS HOUR AT FULL LOAD
2200	240	11.9	9.2	20	151
4200	240	22.8	17.5	30	287
5200	240	28.2	21.7	40	355
6250	240	33.9	26.0	50	427
8250	240	44.7	34.4	60	564
10500	240	56.9	43.8	80	717
12500	240	62.7	52.1	100	854

NOTES

- Input Current = Output Current + Max Charge Current
- Suggested Feed Breaker sizes are rounded up in 10 Amp increments
- Input Power requires 3 wires, Neutral and Ground. Neutral is passed through and current carrying - Feeder Neutral to be sized same as line conductors.
- KAIC Rating for all models = 65KAIC (UL rated per UL 61800-5-1)
- Short Circuit current rating = 65KA for ALL models.

DIMENSIONS

2,200VA INVERTER (HORIZONTAL - SIDE BY SIDE)

Battery cabinet mounted to the right side of electronics cabinet for proper battery cable routing from cabinet to cabinet.

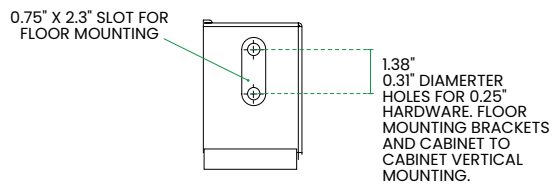
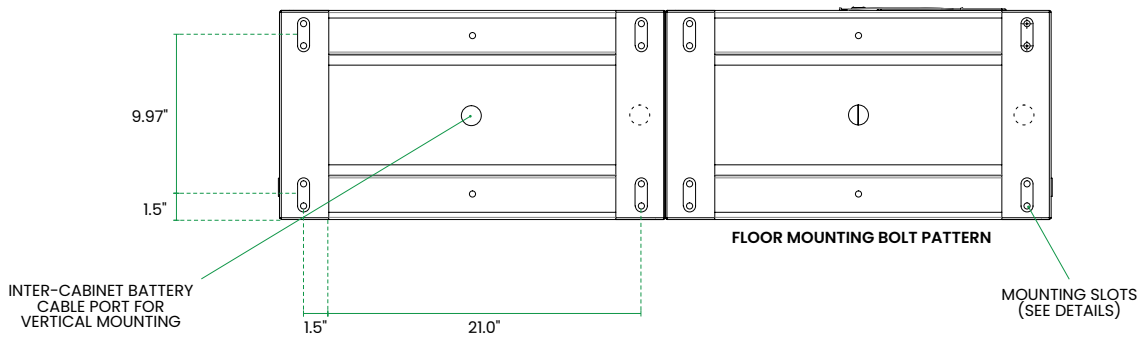
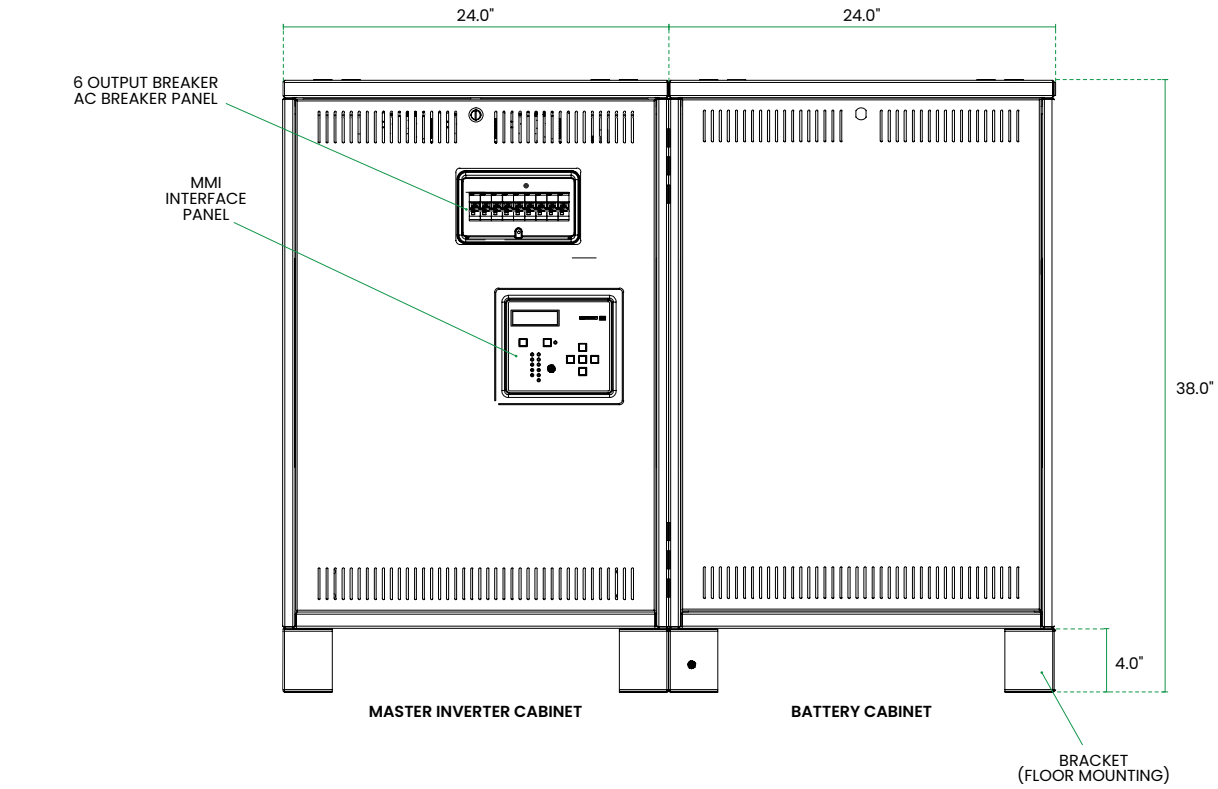

MOUNTING SLOT DETAIL

POWER VA RATING	PHASE CONFIGURATION	INPUT/OUTPUT VOLTAGE	NO. OF BATTERIES	MAX OUTPUT BREAKERS
2200W	SP	120V / 120V / 240V	8	6*

NOTE: Breakers must be a multiple of two to ensure even load distribution.

DIMENSIONS

2,200VA INVERTER WITH SEISMIC BRACKETS

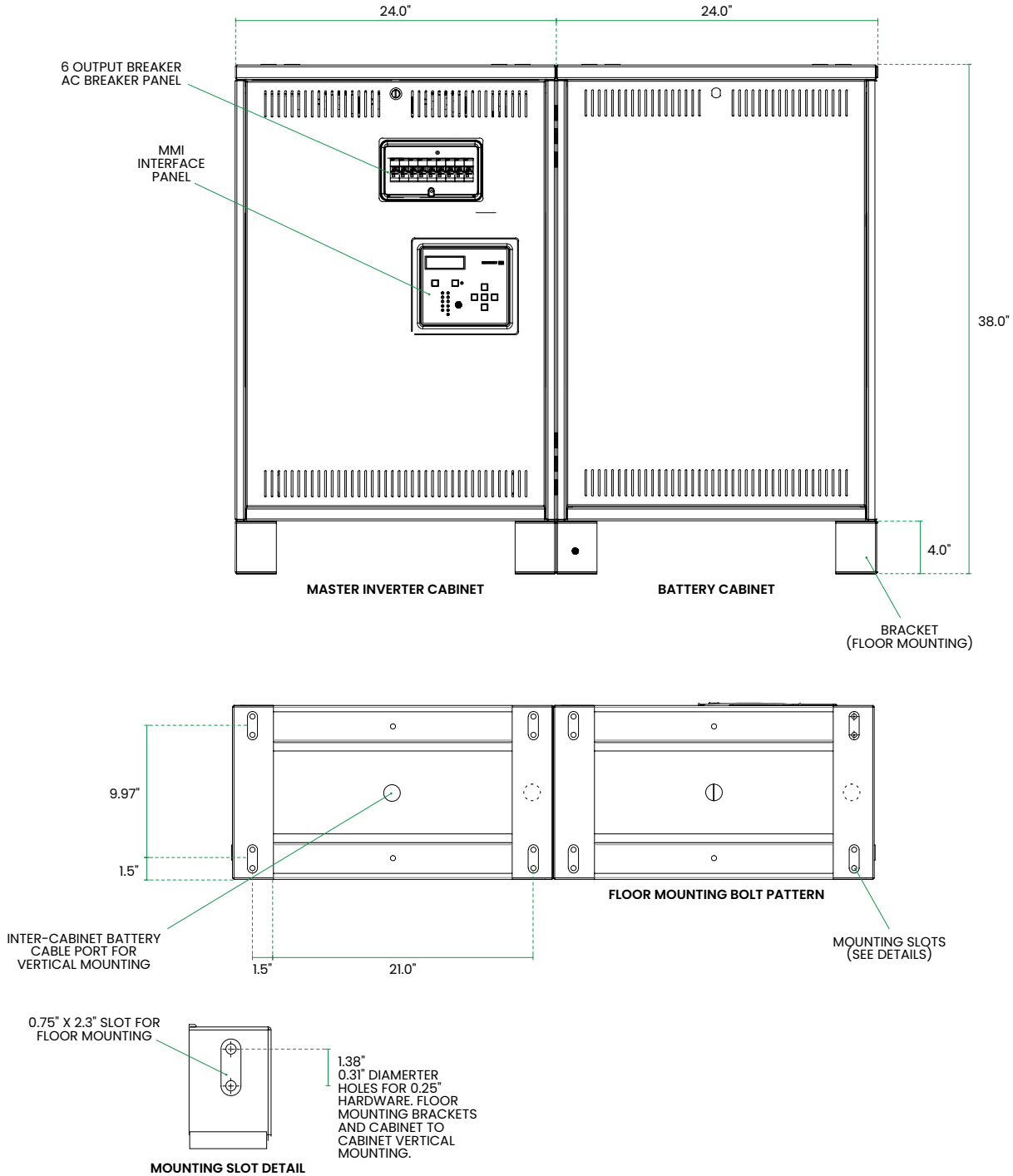

DIMENSIONS

2,200VA INVERTER (VERTICAL - STACKED)

Battery cabinet mounted underneath electronics cabinet for proper battery cable routing from cabinet to cabinet.

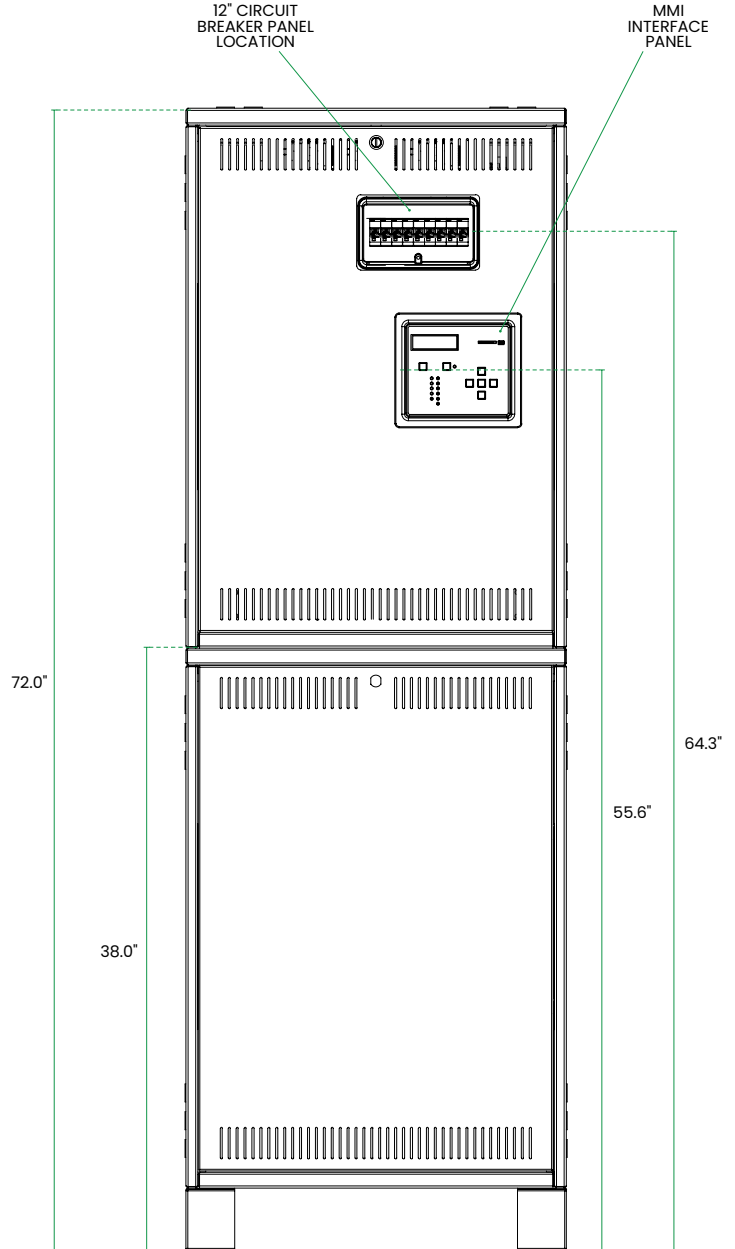
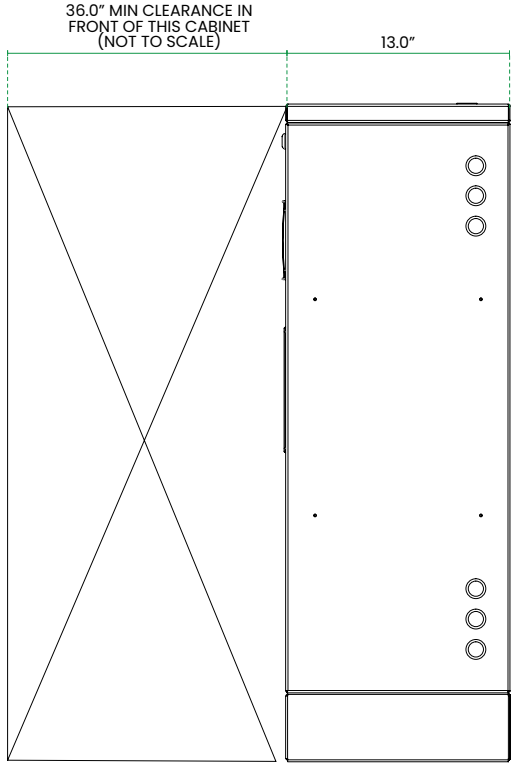

POWER VA RATING	PHASE CONFIGURATION	INPUT/OUTPUT VOLTAGE	NO. OF BATTERIES	MAX OUTPUT BREAKERS
2200W	SP	120V / 120V / 240V	8	6*

NOTE: Breakers must be a multiple of two to ensure even load distribution.

DIMENSIONS

4,200VA - 12,500VA INVERTER

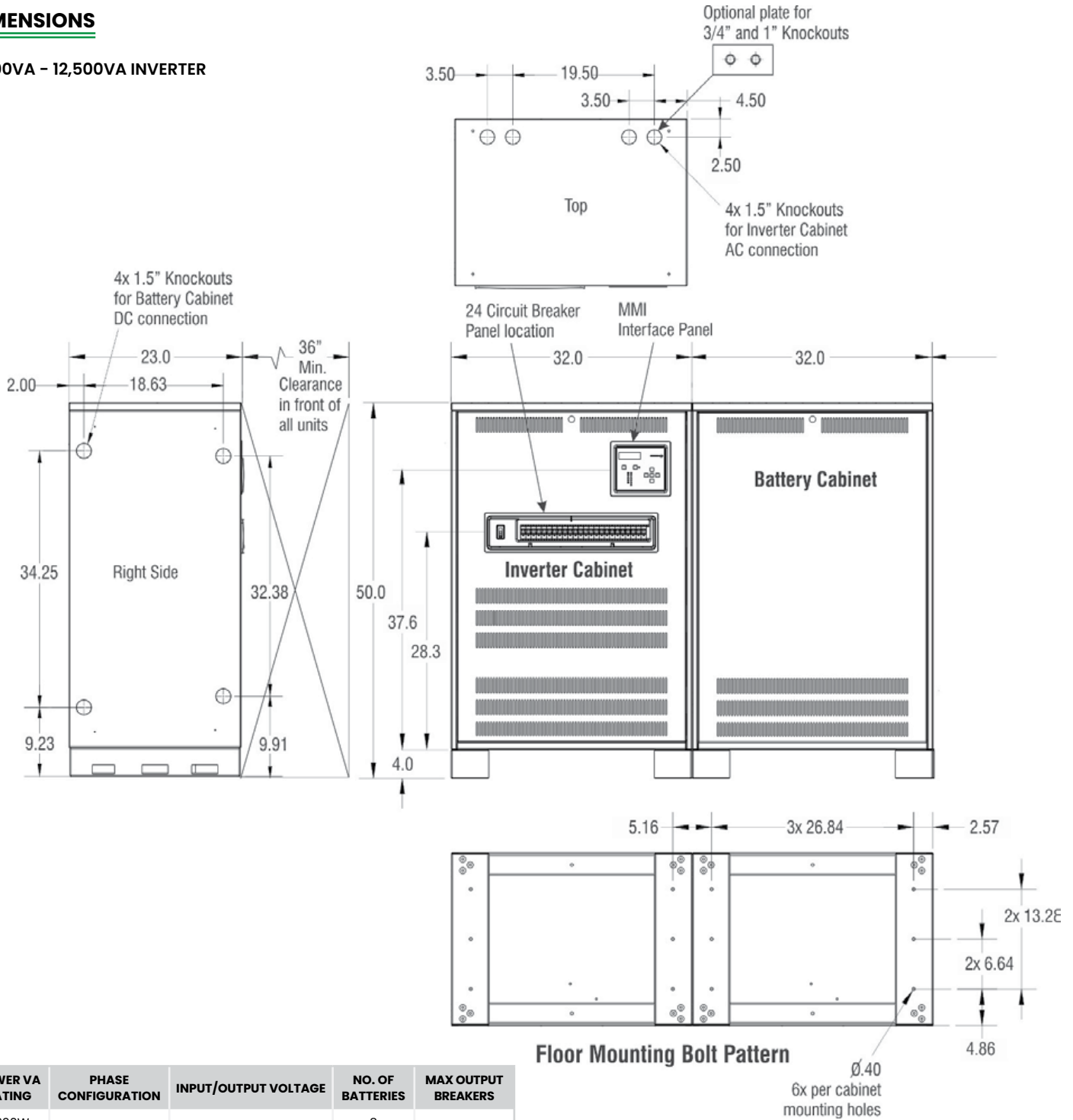

POWER VA RATING	PHASE CONFIGURATION	INPUT/OUTPUT VOLTAGE	NO. OF BATTERIES	MAX OUTPUT BREAKERS
4200W	SP	120V / 120V / 240V	8	24
5200W			10	
6250W			12	
8250W			16	
10500W			20	
12500W			24	

NOTE: Breakers must be a multiple of two to ensure even load distribution.

DIMENSIONS

4,200VA - 12,500VA INVERTER WITH SEISMIC BRACKETS

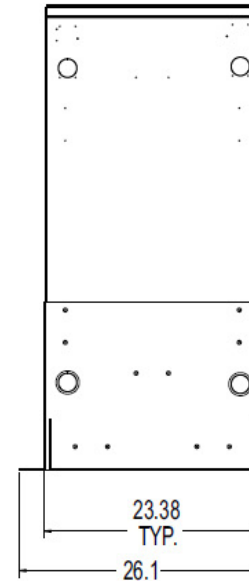
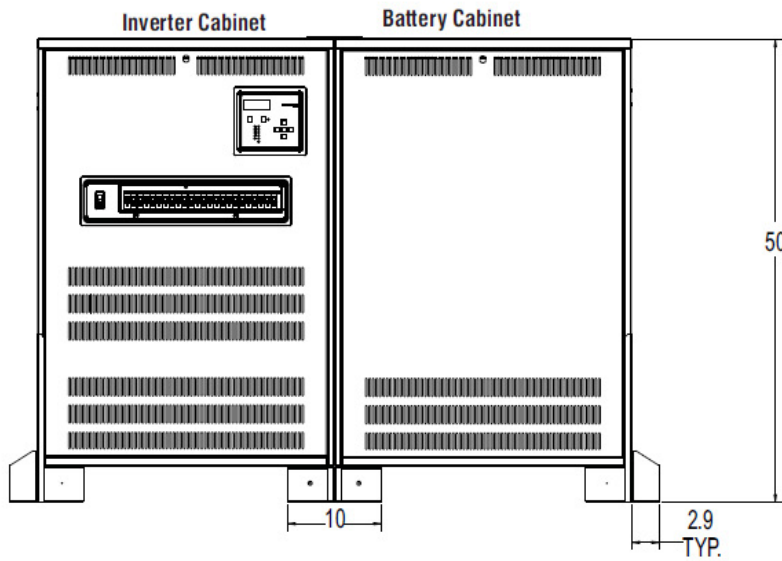
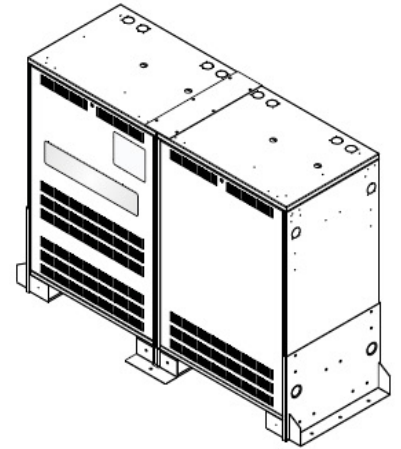
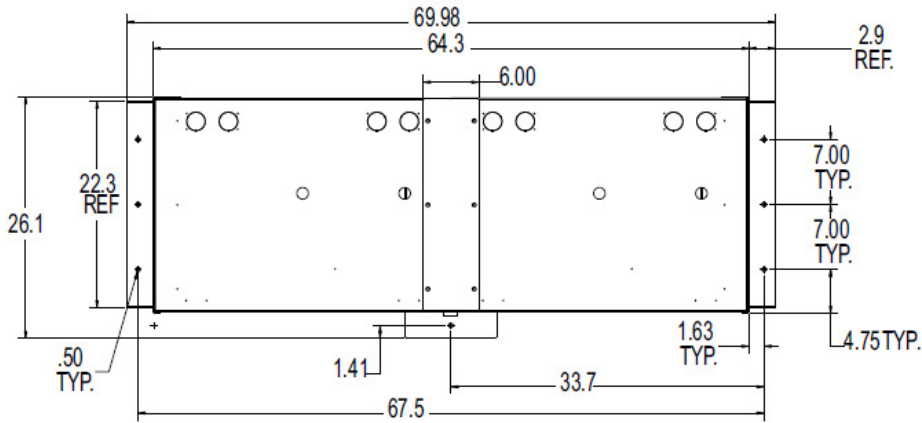

DIMENSIONS

4,200VA - 12,500VA STACKED CONFIGURATION

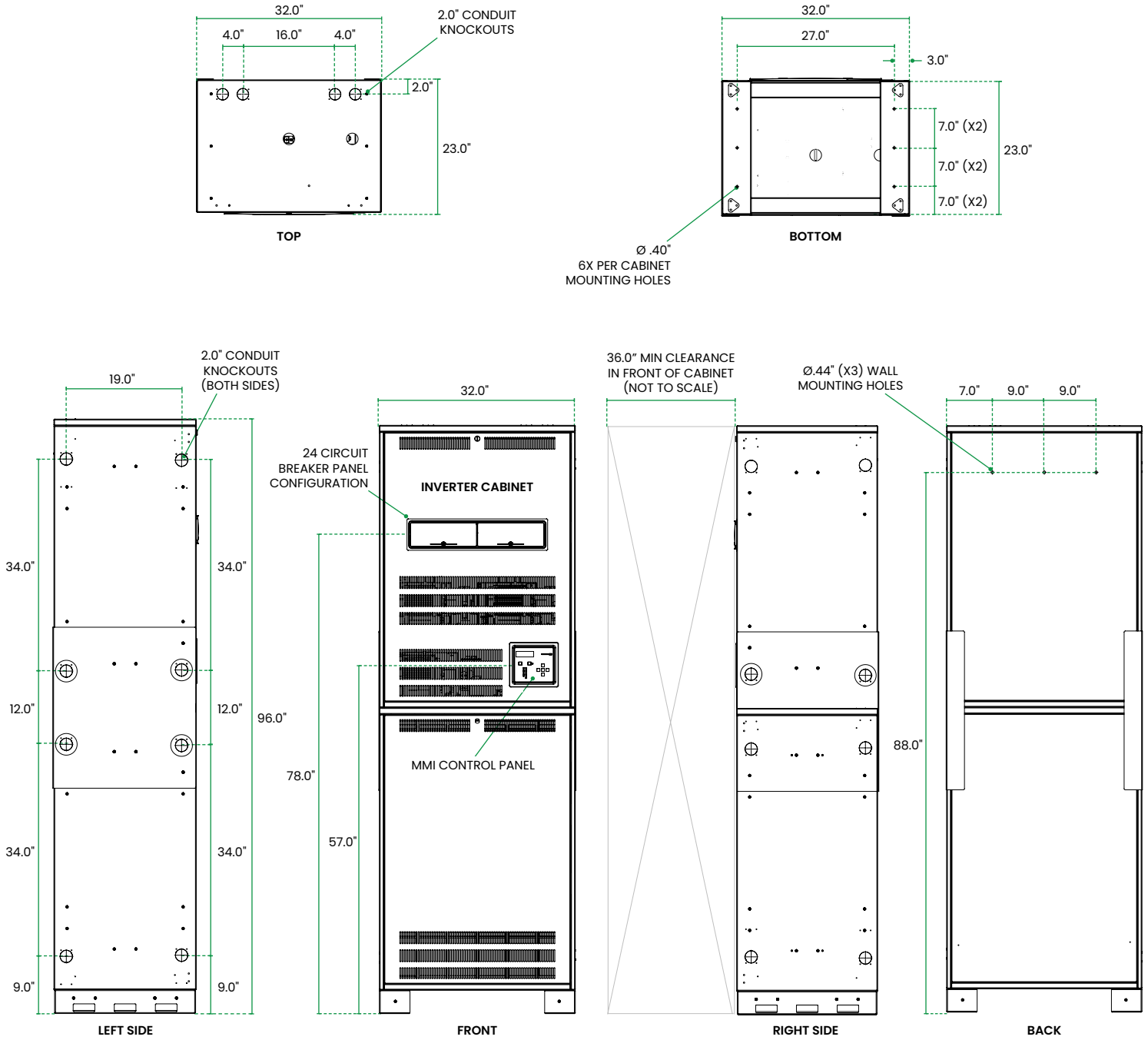

BMS INTERFACE POINTS LIST

POINT NAME	BACNET OBJECT TYPE	BACNET OBJECT ID	MODBUS REGISTER
Inverter	BI	1	10001
Charger	BI	2	10002
AC Present	BI	3	10003
Ready	BI	4	10004
Switched Load	BI	5	10005
Alarm Summary	BI	6	10006
Bypass	BI	7	10007
Circuit Breaker Tip	BI	8	10008
Startup Fault	BI	9	10009
Charger Fault	BI	10	100010
Inverter Fault	BI	11	100011
Input Voltage (Phase A)	AI	1	30001/30002 (FLOAT)
Input Voltage (Phase B)	AI	2	30003/30004 (FLOAT)
Input Voltage (Phase C)	AI	3	30005/30006 (FLOAT)
Output Voltage (Phase A)	AI	4	30007/30008 (FLOAT)
Output Voltage (Phase B)	AI	5	30009/30010 (FLOAT)
Output Voltage (Phase C)	AI	6	30011/30012 (FLOAT)
Output Current (Phase A)	AI	7	30013/30014 (FLOAT)
Output Current (Phase B)	AI	8	30015/30016 (FLOAT)
Output Current (Phase C)	AI	9	30017/30018 (FLOAT)
Battery Voltage	AI	10	30019/30020 (FLOAT)
Battery Current	AI	11	30021/30022 (FLOAT)
Temperature	AI	12	30023/30024 (FLOAT)
Output VA (Phase A)	AI	13	30101/30102 (UINT32)
Output VA (Phase B)	AI	14	30103/30104 (UINT32)
Output VA (Phase C)	AI	15	30105/30106 (UINT32)
Battery Power	AI	16	30107/30108 (UINT32)
System Runtime (Days)	AI	17	30109/30110 (UINT32)
Inverter Runtime (Minutes)	AI	18	30111/30112 (UINT32)
Inverter Runtime (Seconds)	AI	19	30113/30114 (UINT32)
System Events	AI	20	30115/30116 (UINT32)