

LIFELINE CUSTOM GRAPHICS

Self-Luminous Tritium Custom-Wording Sign

The Lifeline LEX Series is a unique, non-electrical self-luminous sign powered by a sealed tritium light source with a 15-year lifespan, requiring no maintenance. Its custom stencil graphics are illuminated against an opaque background for clear visibility. Designed with sustainability in mind, Lifeline signs can be recycled at the end of their lifespan.

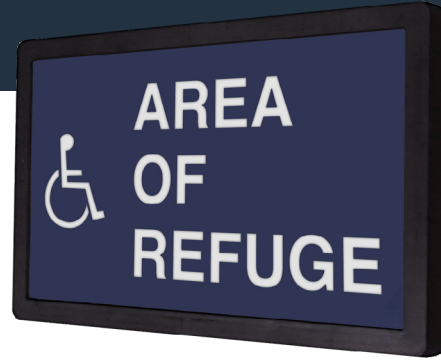

CONSTRUCTION

- Rugged thermoplastic, flame retardant ABS injection molded housing with tamper resistant finishing bezel
- Requires no external light source, electrical power, wiring or batteries
- 12 Year rated service life
- 100% reliable, always on and maintenance free
- Sealed internal construction prevents unauthorized access to light tubes
- NO SERVICEABLE PARTS
- Heavy-duty universal mounting bracket supplied with hardware
- Suitable for wall, ceiling, end mount or optional pendant mounting
- Screen-printed internal legend protected by clear polycarbonate window
- Suitable for clean room applications
- Explosion proof (not a source of ignition)
- Operating temperature -22°F - 149°F

ELECTRICAL

- Non-electrical sustained tritium light source

ORDERING GUIDE

LL-1-R-W-PA "Specify Graphics"

MODEL	NO. OF FACES	BACKGROUND COLOR	FRAME COLOR	OPTIONS	ORDERING NOTES
LL	1 Single Face	R Red	W White	VS Polycarbonate Vandal Shield with Torx Head Screws PA 12" Swivel Pendant PB 24" Swivel Pendant PC 36" Swivel Pendant PD 48" Swivel Pendant CTSA 6" Forward Leading Symbol of Accessibility ¹	¹ Meets CT H.B. No 5050, Public Act No. 16-78
	2 Double Face	G Green B Black	B Black		
LL					

Fill in fields from categories above and complete type and part number.

Type No:	Full Part No:
----------	---------------

DIMENSIONS

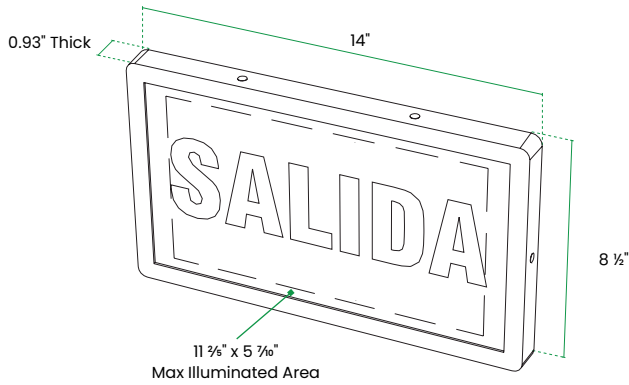

ADDITIONAL IMAGES

SIGN IN DARK ENVIRONMENT



MOUNTING

EDGE OR PENDANT MOUNT

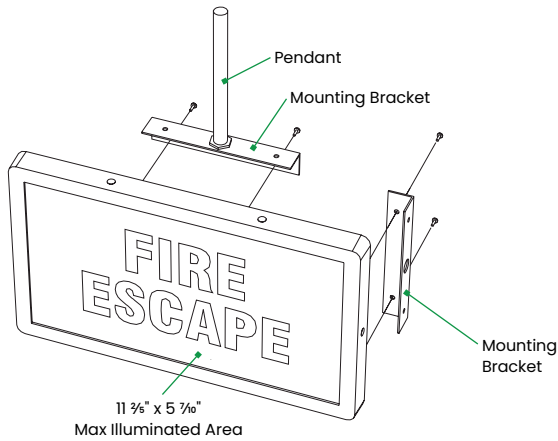

WALL SURFACE MOUNT

Note for wall mount units:
Wire Guard available, see
data sheet **WG-VS**

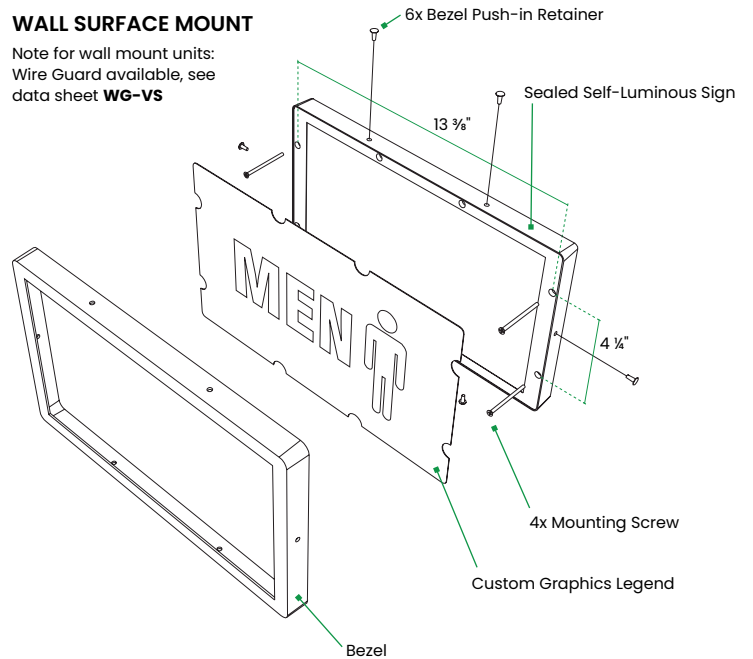

CTSA OPTION

Now available with CTSA option which meets H.B. No. 5050, P.A. no. 16-78

