



# EVENLITE

LIFE SAFETY LIGHTING SOLUTIONS

## RAZOR-3 SERIES

### RZR3 DIE CAST ALUMINUM EXIT SIGN / FIXTURE

#### INSTALLATION AND OPERATING INSTRUCTIONS

#### IMPORTANT SAFEGUARDS

When using electrical equipment, basic safety precautions should always be followed including the following:

#### READ AND FOLLOW ALL SAFETY INSTRUCTIONS:

1. DO NOT use outdoors.
2. DO NOT mount near gas or electric heaters.
3. Equipment should be mounted in locations and at heights where it will not be readily subject to tampering by unauthorized personnel.
4. The use of accessory equipment is not recommended by the manufacturer. Use of such equipment may cause an unsafe condition.
5. DO NOT use this equipment for other than intended use.
6. Conduct periodic visibility tests in accordance with the applicable installation code (such as NFPA 101).
7. Supply connections MUST be made inside the junction box.
8. Install using recommended junction box ONLY.
9. Servicing of this equipment should be performed by a qualified service personnel.
10. Install sign indoors only where not exposed to direct unfiltered sunlight, liquid spray or temperatures outside of the range of 10°C to 40°C.
11. Before installing unit, disconnect power at breaker panel.

**SAVE THESE INSTRUCTIONS**

**CONSERVER LA FICHE D'INSTRUCTION**

**2575 Metropolitan Drive • Trevose • PA 19053 U•S•A**

**Telephone: (215) 244-4204 • Fax: (215) 244-4208**

# RAZOR-3 SERIES

## RZR3 DIE CAST ALUMINUM EXIT SIGN / FIXTURE

### TABLE OF CONTENTS

Section	1.0	Installation Preparation	Page 3
	1.1	Knockouts and Chevrons	Page 3
	1.2	Transformer Wiring	Page 4
Section	2.0	Installation Options	Page 5
	2.1	Back Mount Installation	Page 5
	2.2	Canopy & Top Mount Installation	Page 6
	2.3	End Mount Installation	Page 7
Section	3.0	Master-Remote Sign Configuration	Page 8
Section	4.0	Diagnostics	Page 10
	5.1	Non-Self Testing/Diagnostic Models	Page 10
	5.2	Self Testing/Diagnostic Models	Page 10
Section	5.0	Options	Page 11
	5.1	Flasher/Fire Alarm	Page 11
	5.2	Remote Exit and Lamp Operation	Page 11
	5.3	Infra Red Remote Testing	Page 11

## SECTION 1.0: Installation Preparation

This Exit Sign is designed to be mounted to a junction box (supplied by others). It can be either back, top or side mounted. The single face unit back mounts to a standard 4" Square (4S) junction box. Dual circuit options will require a deep junction box.

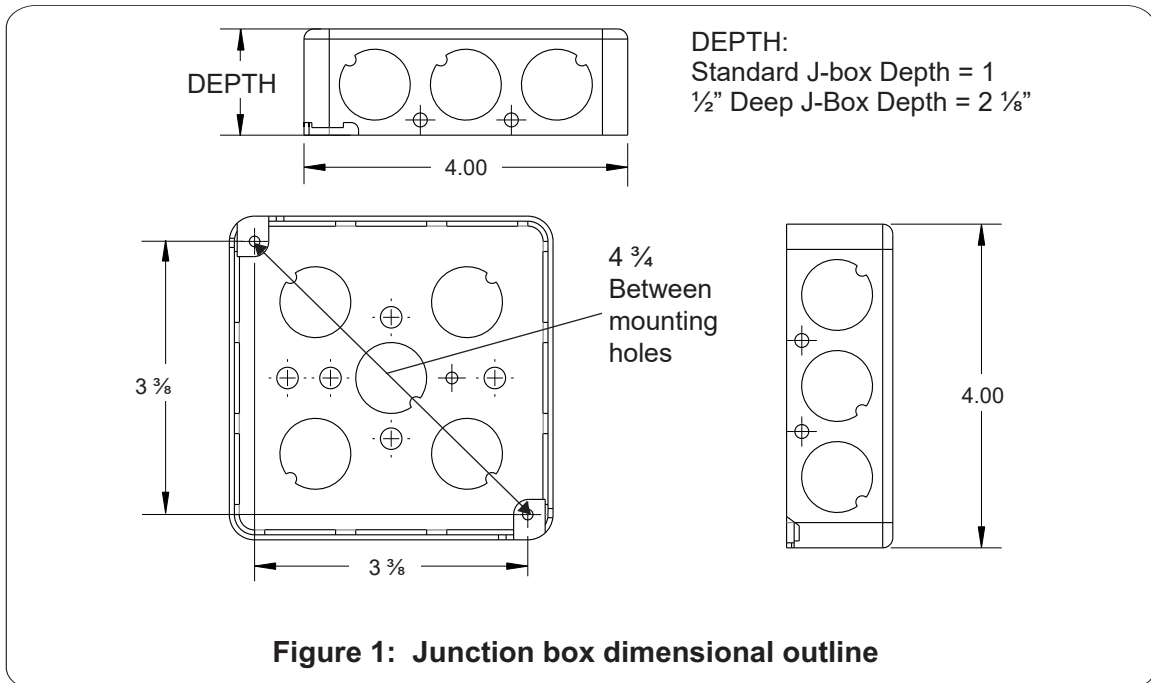

## SECTION 1.1: Knockouts and Chevrons

1. Open enclosure and separate panels using a flat blade screw driver (as shown below).

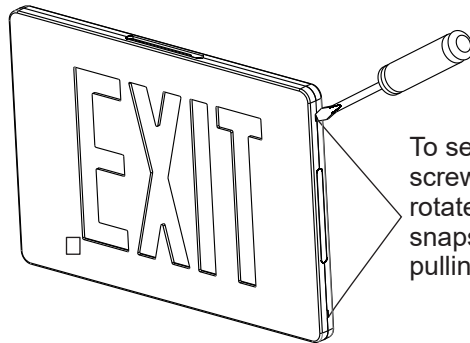

To separate the housing, insert a flat blade screwdriver into the 4 slots on the edge and rotate the blade gently so that the housings snaps apart. Repeat on all sides before pulling apart.

**Figure 2: Opening the sign**

2. Support rear panel on spacers and punch out appropriate knockouts to fit junction box.

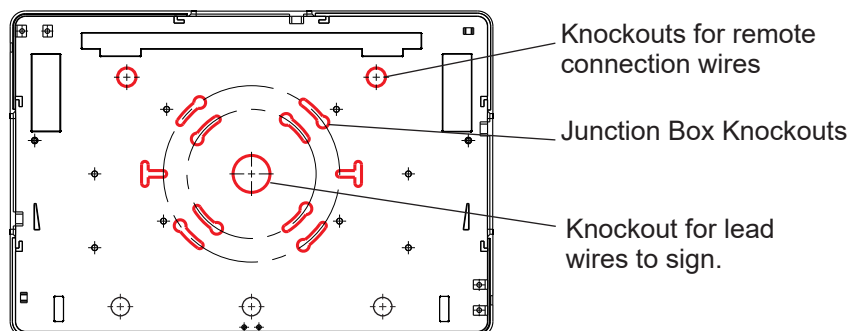

**Figure 3: Rear Panel Knock Outs**

3. To remove directional indicators, remove light guide assembly and diffusers and set aside. Support front cover and knock out desired indicator(s). Support front cover and knock out desired indicator(s).

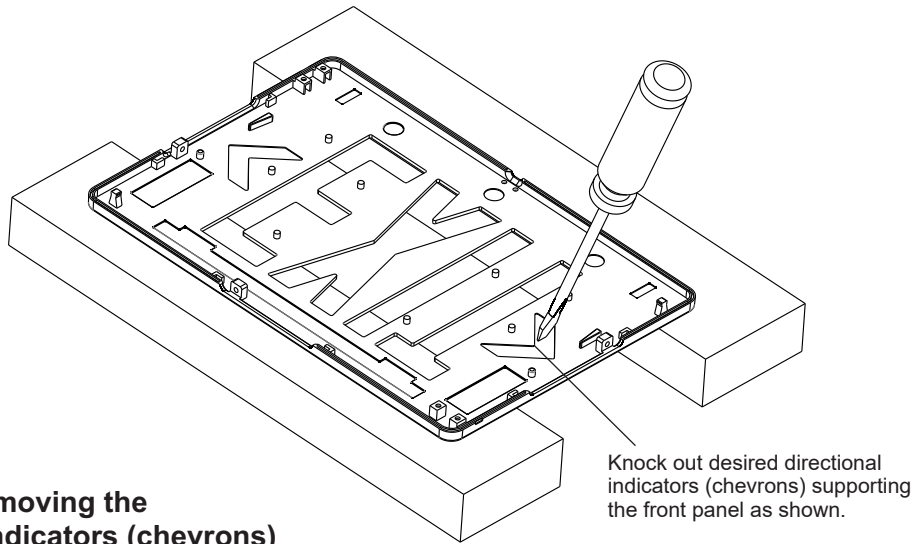
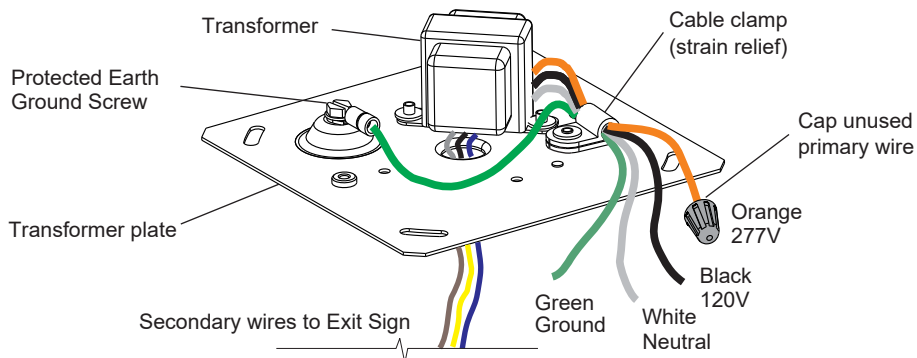

**Figure 4: Removing the directional indicators (chevrons)**

## SECTION 1.2: Transformer Wiring

**\*\*\*Before installing unit, disconnect power at breaker panel\*\*\***

**AC Single Circuit Input:** The transformer plate assembly will be provided assembled as shown below. Connect lead wires to feed wires in 1 ½" deep junction box.



**Figure 5: Single Circuit Application - Lead wire connections to transformer**

**AC Dual Circuit Input:** Utility Power and Emergency Power can be connected to EITHER transformer. Mixed voltages may be used. (Example: 120V Utility Power, 277V Emergency Power)

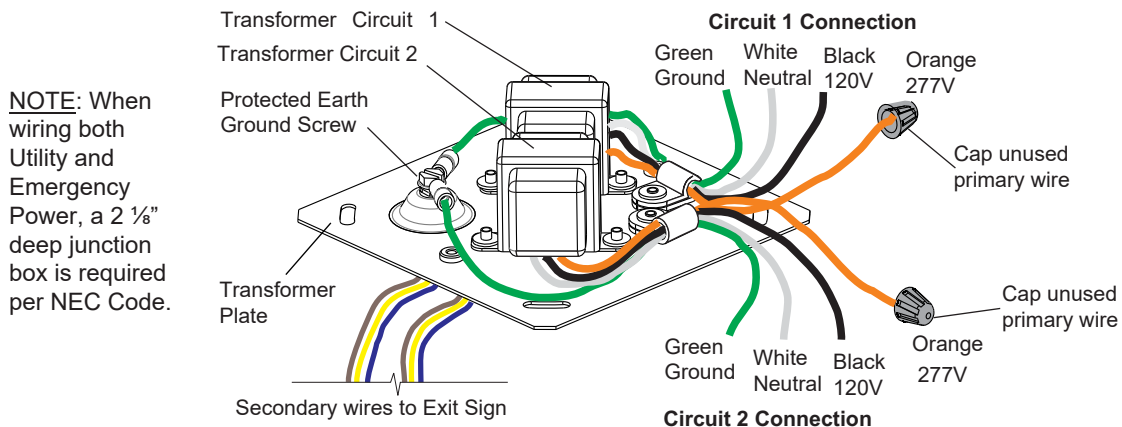

**Figure 6: Dual Circuit Application - Lead wire connections to transformers**

## SECTION 2.0: INSTALLATION OPTIONS

The Razer 3 Series has several different Mounting options available to fit a wide variety of applications.

Those options are:

1. Back Mount Installation (See Section 2.1)
2. Canopy/Top Mount Installation (See Section 2.2)
3. End Mount Installation (See Section 2.3)

## SECTION 2.1: BACK MOUNT INSTALLATION (SINGLE FACE SIGN)

1. Secure spider plate to junction box. Route transformer's secondary leads through center knockout of the rear panel.
2. Place the filler plates in rear panel as per Detail B.
3. Terminate transformer leads to light guide assembly, per Detail A below.
4. Route wires between the rear panel and the white reflector. The wires should not be visible when looking at the sign from the front face.
5. Snap on Front Panel with the colored diffuser.

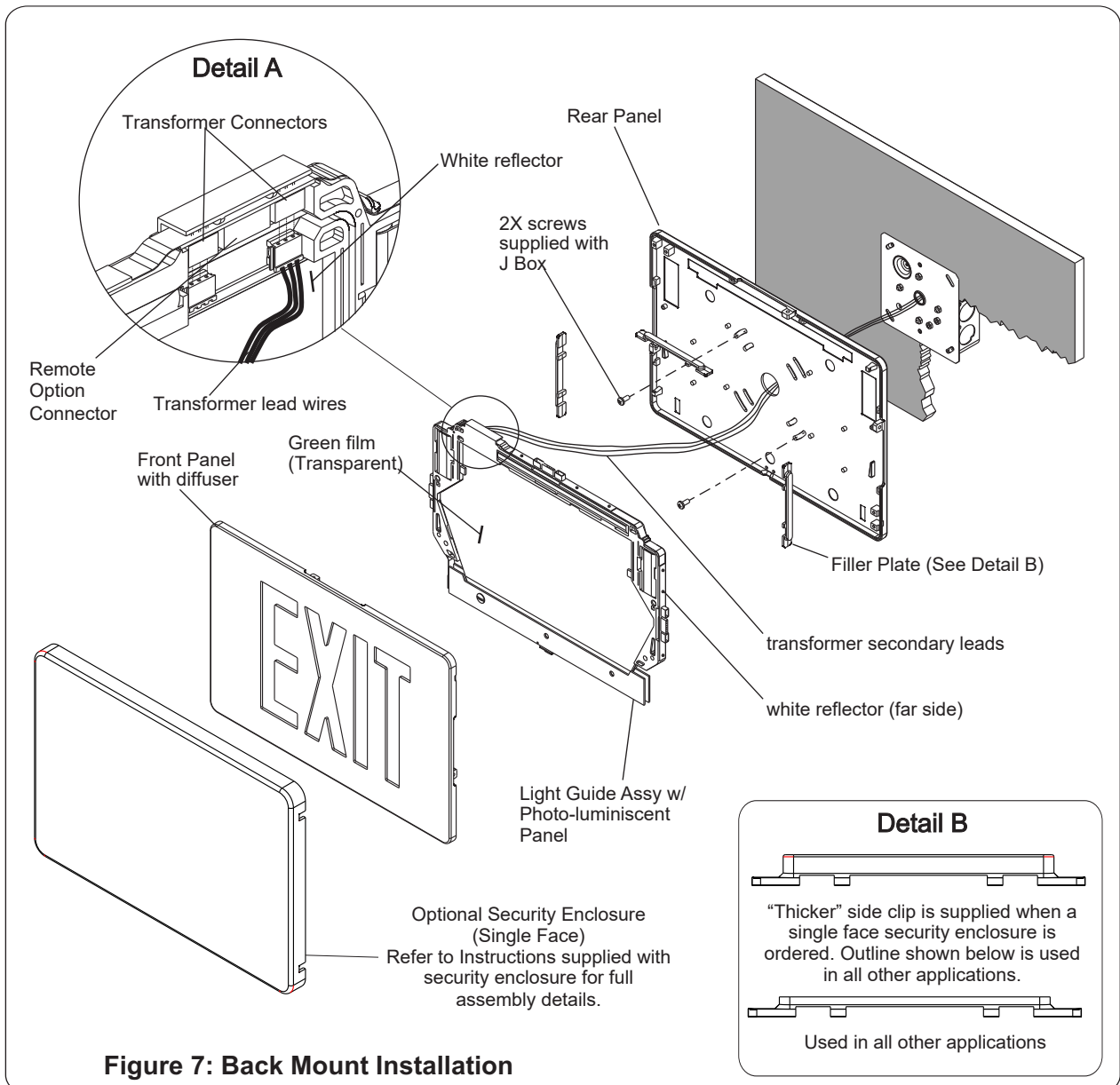

**Figure 7: Back Mount Installation**

## SECTION 2.2: CANOPY & TOP MOUNT INSTALLATION (SINGLE OR DOUBLE FACE SIGNS)

1. Secure transformer plate to junction box. Guide transformer secondary leads through canopy and connect to sign.
2. Secure canopy to sign and then fasten to spider plate. If an optional security cover will be utilized, it must be assembled to sign prior to securing the canopy to the sign.

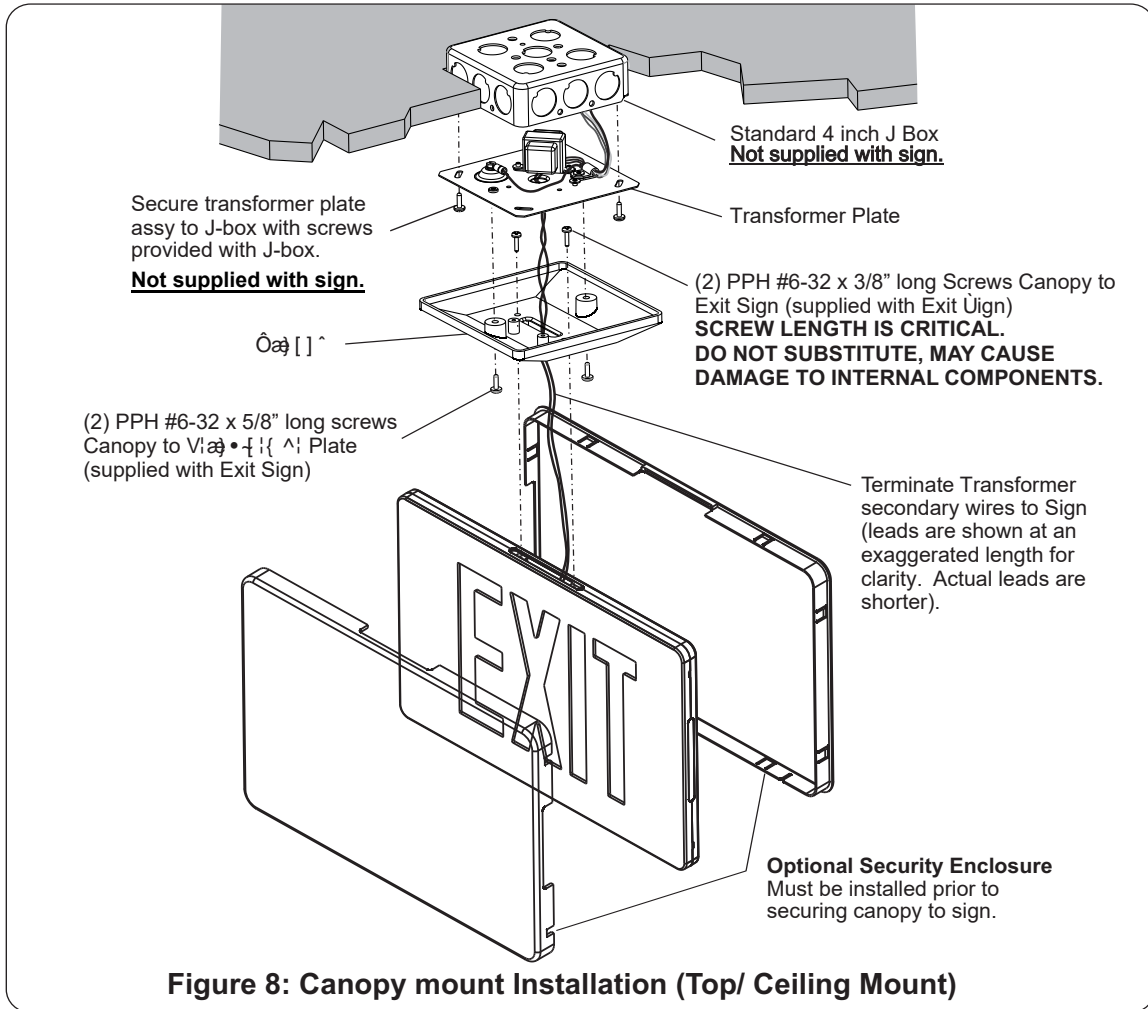

## SECTION 2.3: END MOUNT INSTALLATION

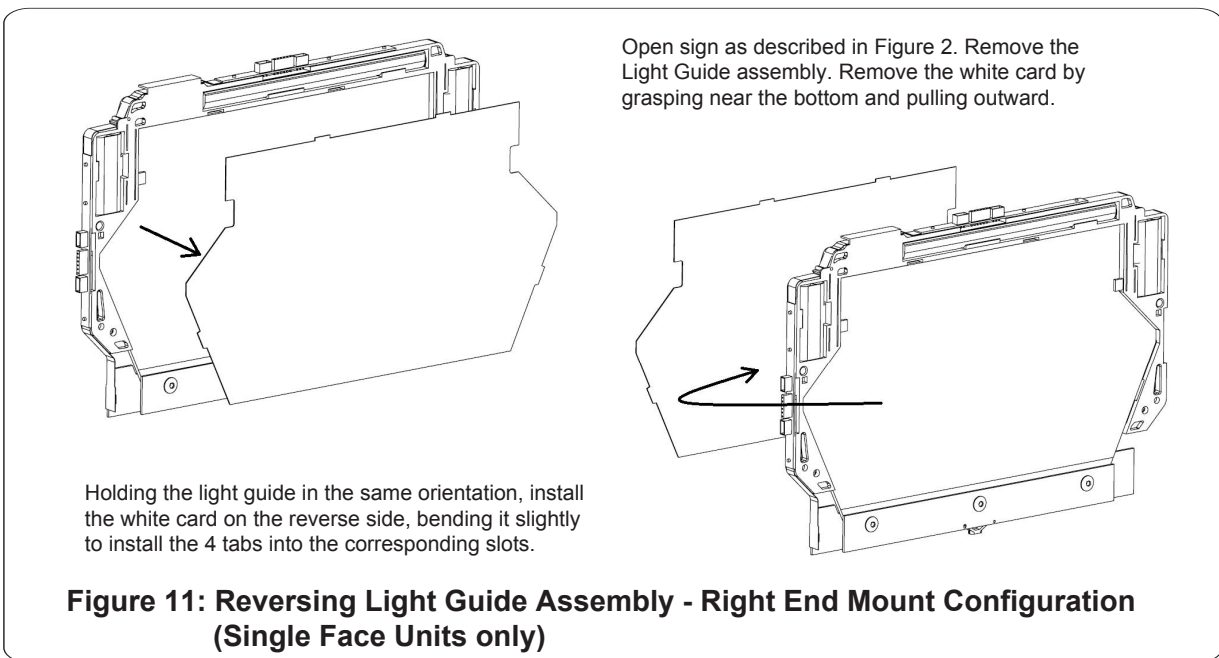
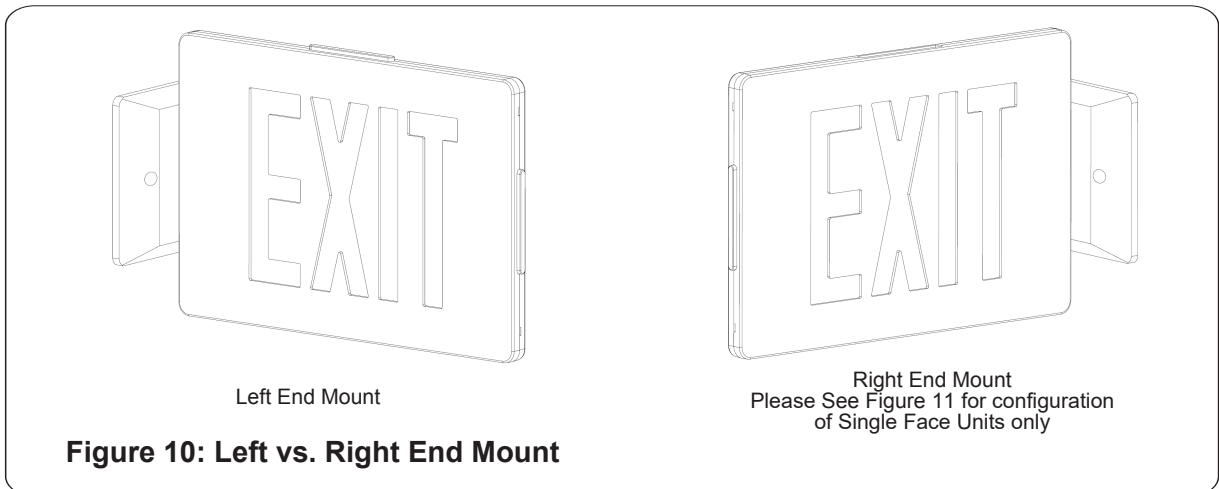
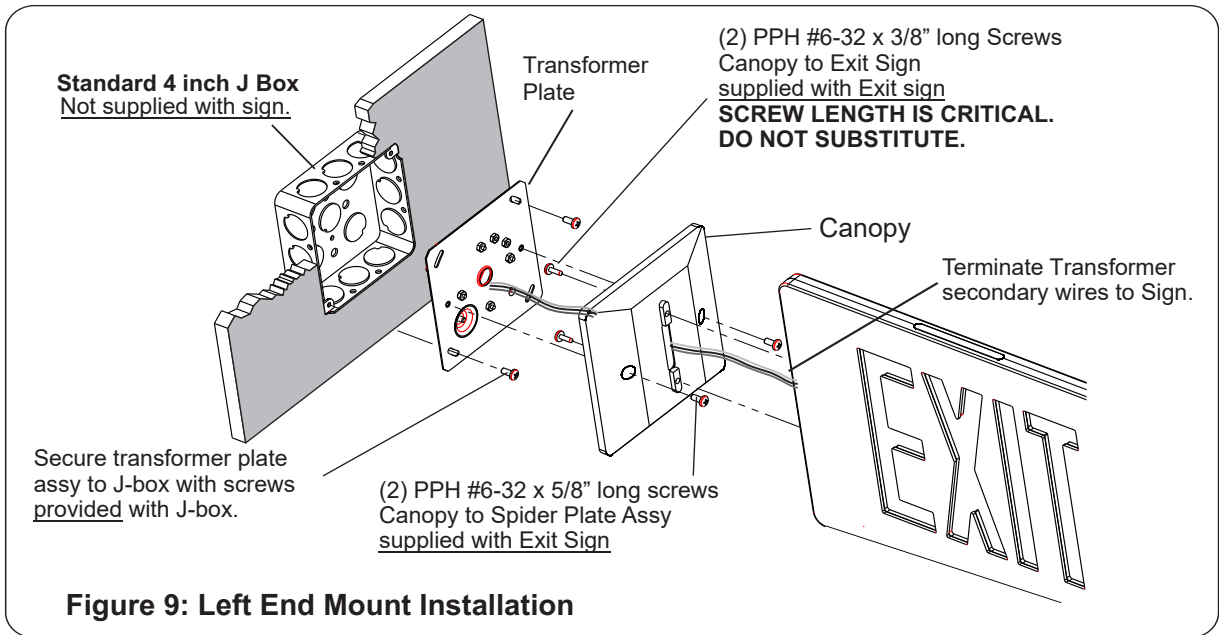

## SECTION 3.0: MASTER-REMOTE SIGN CONFIGURATION

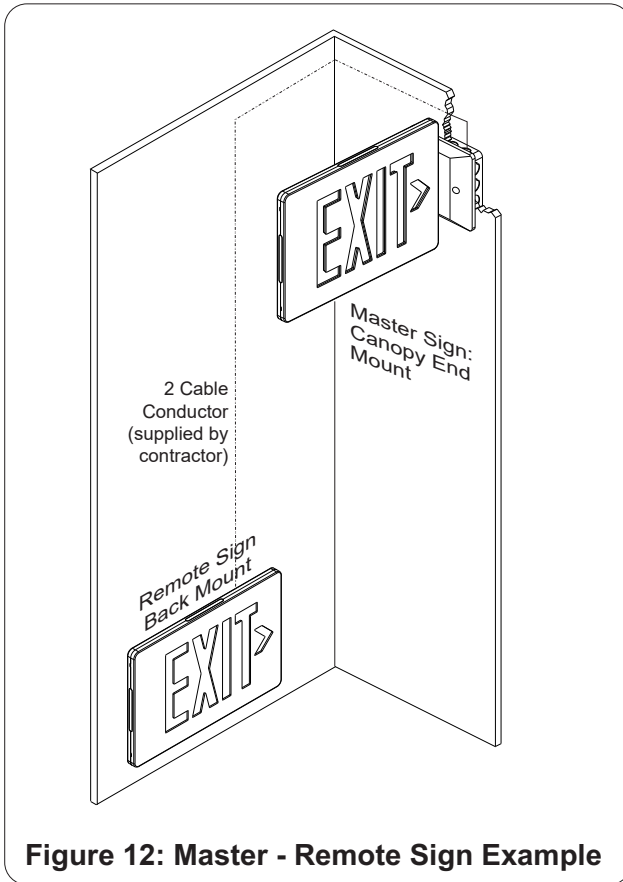

The Master - Remote product (RZMR3) is supplied with 2 signs. The master sign (Figure 13) is provided with a system battery, spider plate assembly (for power) and an option connector used to connect the two signs.

The remote sign (Figure 14) is assembled in the same manner as the master sign, without a spider plate assembly. An option connector is also installed in the remote sign for interconnection to the master sign.

Interconnect the signs with a 2-conductor cable (**20 awg minimum, supplied by contractor**), per the National Electric Code, observing correct polarity. The run should be a distance of **50 feet or less**.

To install remote lamp (3.6V, 2W max - not shown), the option connector is installed similarly in the master sign as shown in Figure 13. Terminate remote lamp leads to the option connector in mating pins labeled "Remote Lamp". Remote Lamp **max mounting height to be 11ft** or the equivalent.

**Figure 12: Master - Remote Sign Example**

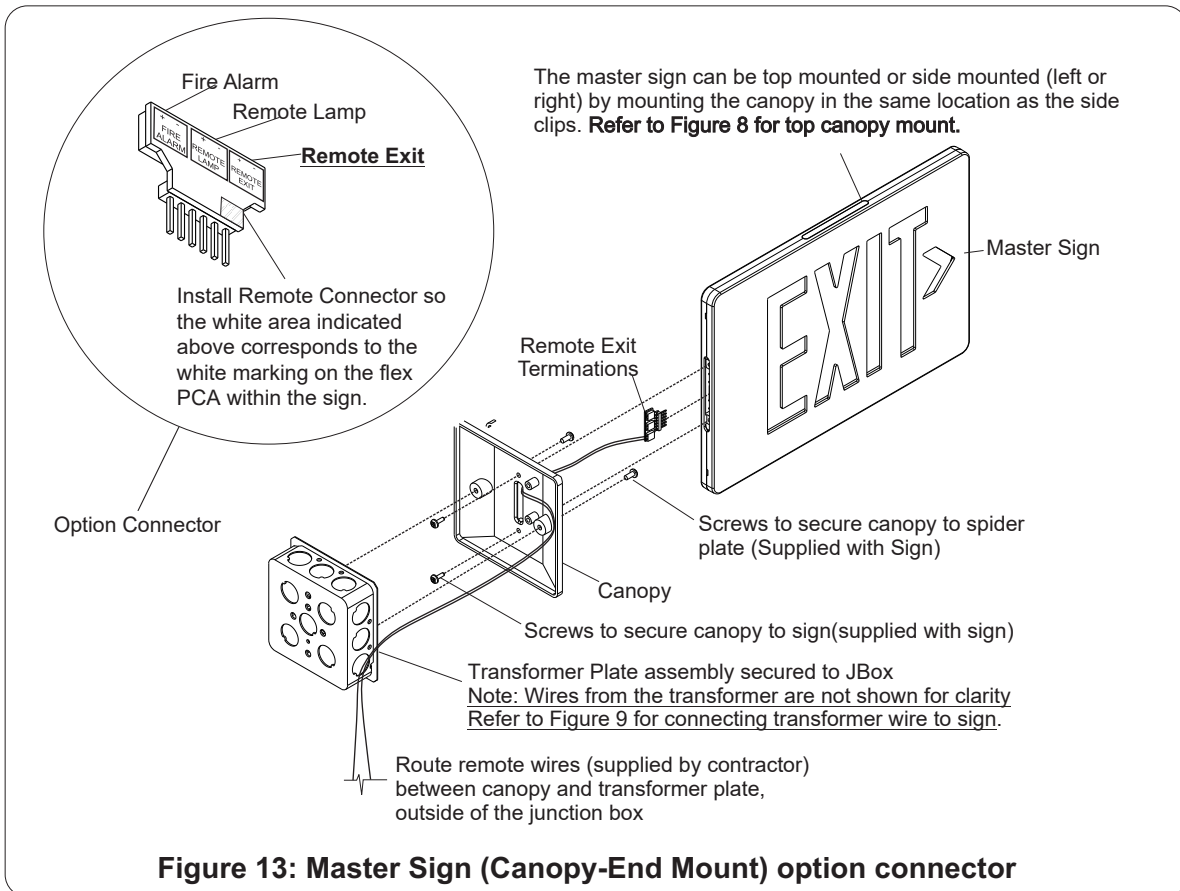

**Figure 13: Master Sign (Canopy-End Mount) option connector**



Route remote wire (supplied by contractor), from master sign to remote sign via the knock out in the rear panel. The remote sign can be mounted to a junction box (as shown) or secured safely to the wall using anchors. The remote option printed circuit assembly should be installed into the sign as shown below. The text legend on the PCA should be visible when looking at the rear of the light guide assembly.

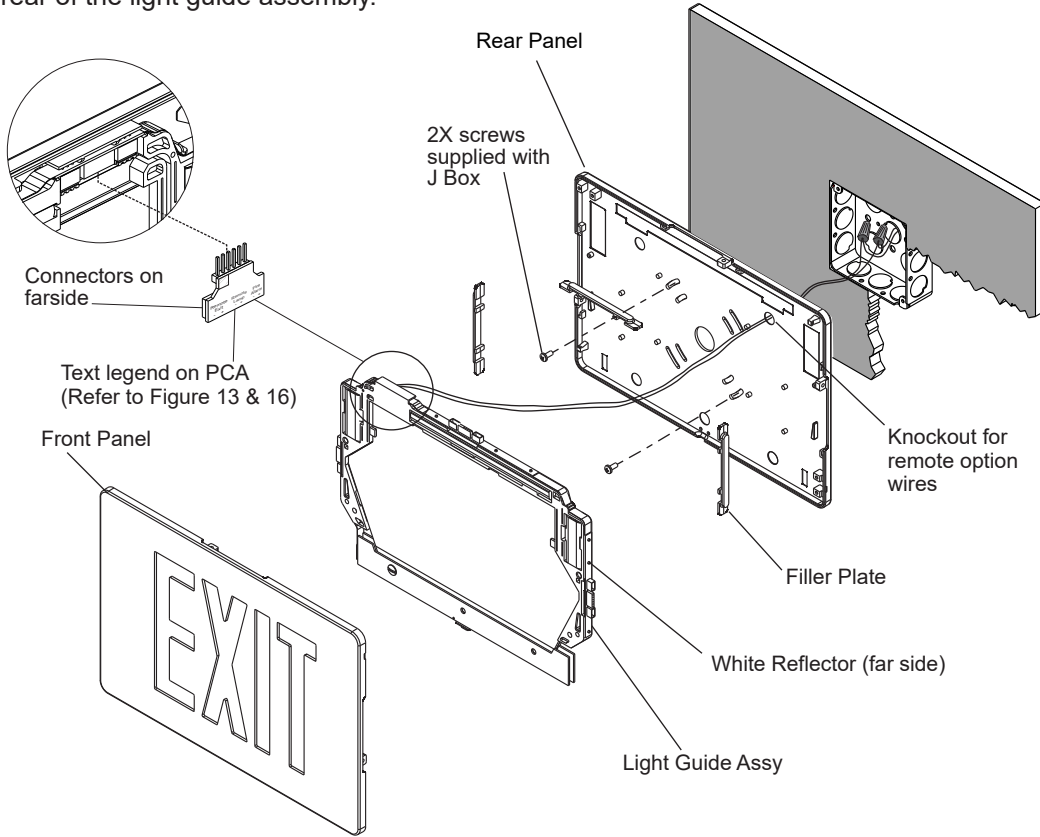

**Figure 14: Remote Sign (Back Mount) Installation**

The System battery is supplied with the sign for emergency backup configurations. Supplemental batteries are provided with the sign when Remote Capacity/ Lamp is ordered.

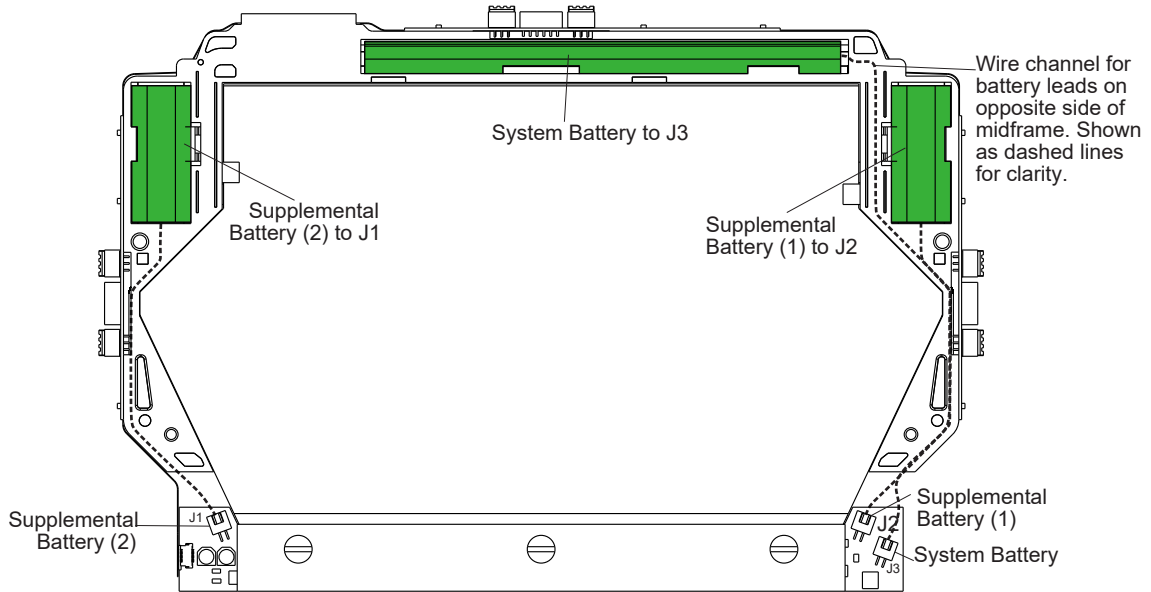

**NOTE:** This product contains Ni-MH batteries. Used batteries may not be disposed of in the municipal solid waste stream. Ni-MH batteries must be recycled or disposed of properly. For information on local recycling drop-off points, phone toll free 1-800-BATTERY (1-800-228-8379).

**Figure 15: System / Remote Lamp Battery Replacement**

## SECTION 4.0: DIAGNOSTICS

For units with Self-Testing/ Self Diagnostics option, refer to the section on next page for operating instructions. Battery back-up units without Self-Testing/ Self Diagnostic option Include a battery diagnostics system which indicates, via flashing of the indicator light, that the battery needs replacement. If flashing occurs after a new installation, check that the battery plug is properly inserted into the circuit board connector (For reference, see Figure 15).

## SECTION 4.1: NON-SELF TEST/ DIAGNOSTIC MODELS

To test battery backup units, use test switch to simulate AC power outage. The indicator light will go out, and the sign will remain lit, indicating transfer to emergency mode. It will remain lit on battery power until switch is released. Release of switch will automatically restore AC/ Battery charge mode, with indicator light on. Testing for longer periods is best accomplished by turning off AC circuit power. Signs should be tested in accordance with National Electric Code and NFPA 101 Life Safety Code Requirements which specify monthly testing for 30 seconds and yearly testing for 90 minutes. Note that the batteries will take some time to reach full charge after a prolonged test, and that the unit cannot provide full duration operation should a real power outage occur before the batteries have had an opportunity to reach full charge. It is recommended that long duration tests be limited to once yearly, and be conducted when the area will be unoccupied afterwards.

## SECTION 4.2: SELF TESTING/ SELF DIAGNOSTIC MODELS

The unit meets the requirement of NFPA 101 for Periodic Testing of Emergency Lighting Equipment. It provides visual indication of unit malfunctions including: Battery Fault, Charger Fault, Transfer Fault, Lamp Fault

**TABLE: DIAGNOSTIC STATUS INDICATIONS**

STATUS DISPLAY	FUNCTION	ACTION
Continuous Green	Battery in Float/Trickle Charge	None
Continuous Red	Battery High Charging	Wait for Green Status
Flashing Green	In Test Mode	Wait for Test to Complete
Alternate Red and Green	Insufficient Charge for User Test	Wait for Full Charge
Red - One Blink ON / Pause	Transfer System Failure Battery	Factory Service
Red - Two Blinks ON / Pause	Failure	Check Connections/Replace Battery
Red - Three Blinks ON / Pause	Charger Failure	Factory Service
Red - Four Blinks ON / Pause	Lamp Failure	Check Remote Connection/ Factory Service

### **SELF TEST**

The unit will perform a self-test and diagnostic function at least once every 28 days. The self test will disable the charger and turn on the LEDs for 30 seconds to check the lamp load, battery and transfer function. The test will be performed only if the battery is fully charged. If not, the test will automatically reschedule. The charger function is monitored while AC is applied.

### **USER TEST**

A user-test may be performed at any time the status display is continuous green. On initial power-up, it could take up to 72 hours for the status display to reach continuous green. With a fully charged battery, pressing the test switch momentarily will initiate a 30 second test. Pressing the test switch continuously for 4 seconds and releasing it will initiate a 90 minute test.

Either Test can be cancelled by pressing the test switch again for 1 second.

**After installation is complete, reapply power and notify the authority having jurisdiction.**

## SECTION 5.0: OPTIONS

### SECTION 5.1: FLASHER/ FIRE ALARM

Battery Backup Emergency signs that are equipped with the FLASH in EMERGENCY MODE OPTION will automatically flash in the emergency mode but not flash on AC operation. AC Only exit signs that are equipped with the flash option will flash continuously while power is supplied.

AC Only and Battery Back up emergency signs that are equipped with the FIRE ALARM SIGNAL MODE FLASH option will automatically flash in both AC and emergency modes upon application of a fire alarm signal to the option connector (Figure 16). The fire alarm signal can be either AC or DC of either polarity, and range from 12 to 24 volts. The current draw from the fire alarm signal is less than 10 milliamps (mA).

Units that include one of the above options, are intended for installation in locations where such features are permitted by local codes.

Flasher Rate: 60 per minute  
Duty Cycle: 25%

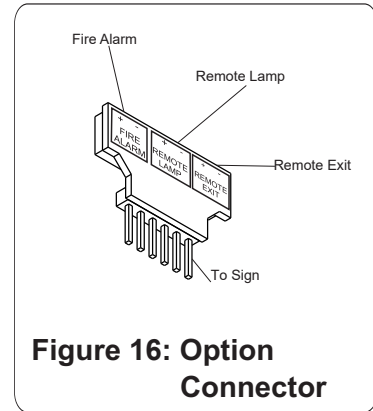

**Figure 16: Option Connector**

### SECTION 5.2: REMOTE EXIT AND LAMP OPERATION

The self-diagnostic system “learns” the lamp and remote sign load when the unit reaches it’s first full charge. It is therefore necessary to have any remote lamp or sign already connected when first applying AC power. Subsequent self-tests and user-test will compare the actual lamp and sign load to the “learned” value.

If the remote lamp and sign load is changed once it has been “learned”, it is necessary to disconnect AC Power at the circuit breaker panel and unplug the internal battery (refer to Figure 15 for details). Once these are reconnected, the unit will “learn” the new lamp and sign load.

### SECTION 5.3: INFRA RED TESTING

To activate TRANSMITTER, remove tab from back of device.

The USER-TEST can be performed up to 20 feet away using the optional “INFRA RED REMOTE TESTING TRANSMITTER”.

By aiming the TRANSMITTER (Figure 17) at the legend face, and pushing either the “30 SECOND” or “90 MINUTE” button for 1 second, the TRANSMITTER can initiate or cancel “30 SECOND” or “90 MINUTE” user tests.

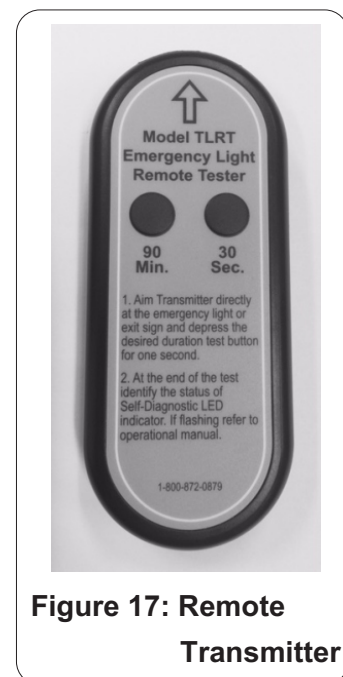

**Figure 17: Remote Transmitter**

THIS PAGE INTENTIONALLY LEFT BLANK