

PROJECT NAME:	APPROVED BY:	
CATALOG NO:	TYPE NO:	

VANDAL RESISTANT SHIELDS

Protect your exit sign from accidental or intentional abuse and unauthorized tampering with Evenlite's polycarbonate vandal cover. Fabricated from clear U.V. stabilized, non-corrosive, polycarbonate material. The vandal resistant shield is easy to install to wall or flat surfaces via the mounting holes and hardware provided.

Compatible with Telesis TLX, and many other signs.

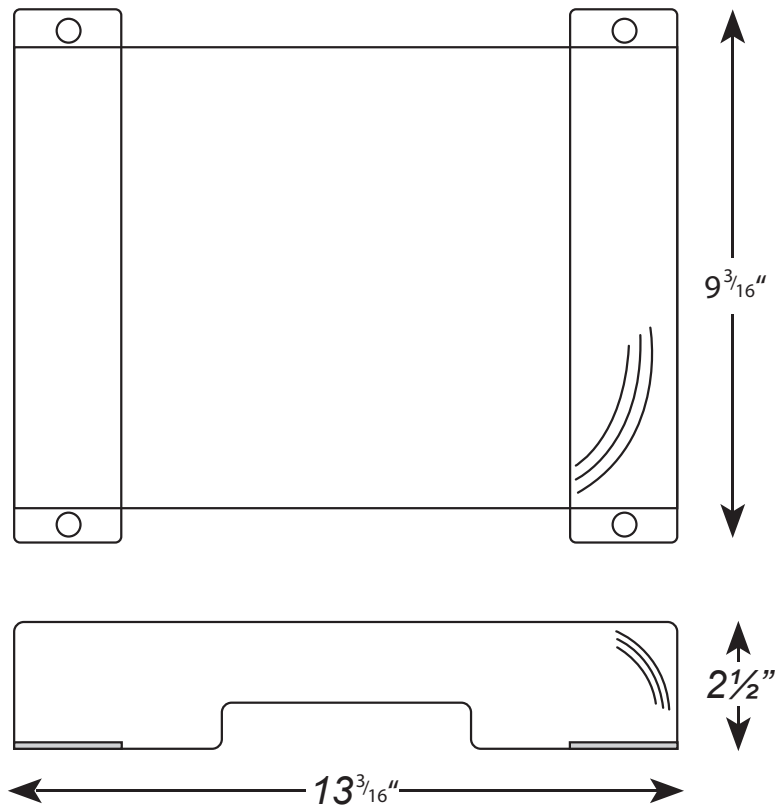

ORDERING GUIDE – VX

Example: VX

Model	Inside Height	Inside Width	Inside Length
VX	2-1/2"	9-3/16"	13-3/16"
VX			

Fill in fields from categories above and complete type and part

Type Number:

Full Part Number:

VX - 12/28/22